



Operation Manual

PRODUCT NAME

Electric Gripper

MODEL/ Series

LEH Series

Applicable models: LEHZ(J), LEHF, LEHS

Z Type (2 Finger Type)

- Standard / LEHZ Series



- With Dust Cover / LEHZJ Series



F Type (2 Finger Type)

- Standard / LEHF Series



S Type (3 Finger Type)

- Standard / LEHS Series

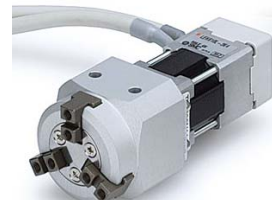

<Controller>
LEC Series

This manual describes the actuators operation in combination with the LEC*6 series controllers. Refer to the manual relevant to the controller being used for full operating instructions.

SMC Corporation

Safety Instructions	3
1. Procedure before operation/simple setting to use straight away ...	5
1.1 Preparation	5
1.2 Controller setting software version	6
1.3 Teaching box	8
2. Electric Gripper/LEHZ Series	10
2.1 LEHZ Series / Standard	10
2.1.1 Specification	10
2.1.2 How to Order.....	11
2.1.3 Construction	12
2.2 LEHZJ Series / With Dust Cover	13
2.2.1 Specification	13
2.2.2 How to Order.....	14
2.2.3 Construction	15
2.2.4 Protection seal to prevent ingress of dust.....	16
3. Electric Gripper/LEHF Series	17
3.1 Specification	17
3.2 How to Order	18
3.3 Construction	19
4. Electric Gripper/LEHS Series	20
4.1 Specification	20
4.2 How to Order	21
4.3 Construction	22
5. Product Outline	23
5.1 System construction	23
5.2 Setting Function	24
5.3 Step data setting method	27
Positioning operation	27
Pushing operation (Gripping operation)	29
Example of step data entry (1)	31
Example of step data entry (2)	32
Example of step data entry (3)	33
Operating procedure and input / output signals for each operation.....	34
5.4 Parameter setting method	36
Initial setting for the basic parameters.....	36
Initial setting for the ORIG parameters.....	39
6. Wiring of cables / Common precautions	40
7. Electric actuators / Common precautions	41
7.1 Design and selection	41

7.2 Mounting.....	42
7.3 Handling	42
7.4 Operating environment	44
7.5 Maintenance	44
8. Electric Gripper/Specific Product Precautions.....	45
8.1 Design and selection	45
8.2 Mounting.....	47
8.3 Handling	51
8.4 Maintenance	54
9. Troubleshooting	55



LEH Series / Electric Gripper Safety Instructions

These safety instructions are intended to prevent hazardous situations and/or equipment damage. These instructions indicate the level of potential hazard with the labels of "Caution," "Warning" or "Danger." They are all important notes for safety and must be followed in addition to International Standards (ISO/IEC), Japan Industrial Standards (JIS)*1) and other safety regulations*2).

*1) ISO 4414: Pneumatic fluid power -- General rules relating to systems

ISO 4413: Hydraulic fluid power -- General rules relating to systems

IEC 60204-1: Safety of machinery -- Electrical equipment of machines (Part 1: General requirements)

ISO 10218-1992: Manipulating industrial robots -- Safety

JIS B 8370: General rules for pneumatic equipment.

JIS B 8361: General rules for hydraulic equipment.

JIS B 9960-1: Safety of machinery -- Electrical equipment for machines. (Part 1: General requirements)

JIS B 8433-1993: Manipulating industrial robots - Safety. etc.

*2) Labor Safety and Sanitation Law, etc.



Caution

Caution indicates a hazard with a low level of risk which, if not avoided, could result in minor or moderate injury.



Warning

Warning indicates a hazard with a medium level of risk which, if not avoided, could result in death or serious injury.



Danger

Danger indicates a hazard with a high level of risk which, if not avoided, will result in death or serious injury.

Warning

1. The compatibility of the product is the responsibility of the person who designs the equipment or decides its specifications.

Since the product specified here is used under various operating conditions, its compatibility with specific equipment must be decided by the person who designs the equipment or decides its specifications based on necessary analysis and test results.

The expected performance and safety assurance of the equipment will be the responsibility of the person who has determined its compatibility with the product.

This person should also continuously review all specifications of the product referring to its latest catalog information, with a view to giving due consideration to any possibility of equipment failure when configuring the equipment.

2. Only personnel with appropriate training should operate machinery and equipment.

The product specified here may become unsafe if handled incorrectly.

The assembly, operation and maintenance of machines or equipment including our products must be performed by an operator who is appropriately trained and experienced.

3. Do not service or attempt to remove product and machinery/equipment until safety is confirmed.

The inspection and maintenance of machinery/equipment should only be performed after measures to prevent falling or runaway of the driven objects have been confirmed.

When the product is to be removed, confirm that the safety measures as mentioned above are implemented and the power from any appropriate source is cut, and read and understand the specific product precautions of all relevant products carefully.

Before machinery/equipment is restarted, take measures to prevent unexpected operation and malfunction.

4. Contact SMC beforehand and take special consideration of safety measures if the product is to be used in any of the following conditions.

1) Conditions and environments outside of the given specifications, or use outdoors or in a place exposed to direct sunlight.

2) Installation on equipment in conjunction with atomic energy, railways, air navigation, space, shipping, vehicles, military, medical treatment, combustion and recreation, or equipment in contact with food and beverages, emergency stop circuits, clutch and brake circuits in press applications, safety equipment or other applications unsuitable for the standard specifications described in the product catalog.

3) An application which could have negative effects on people, property, or animals requiring special safety analysis.

4) Use in an interlock circuit, which requires the provision of double interlock for possible failure by using a mechanical protective function, and periodical checks to confirm proper operation.



LEH Series / Electric Gripper Safety Instructions

Caution

The product is provided for use in manufacturing industries.

The product herein described is basically provided for peaceful use in manufacturing industries.

If considering using the product in other industries, consult SMC beforehand and exchange specifications or a contract if necessary.

If anything is unclear, contact your nearest sales branch.

Limited warranty and Disclaimer/Compliance Requirements

The product used is subject to the following “Limited warranty and Disclaimer” and “Compliance Requirements”.

Read and accept them before using the product.

Limited warranty and Disclaimer

The warranty period of the product is 1 year in service or 1.5 years after the product is delivered.*3) Also, the product may have specified durability, running distance or replacement parts. Please consult your nearest sales branch.

For any failure or damage reported within the warranty period which is clearly our responsibility, a replacement product or necessary parts will be provided.

This limited warranty applies only to our product independently, and not to any other damage incurred due to the failure of the product.

Prior to using SMC products, please read and understand the warranty terms and disclaimers noted in the specified catalog for the particular products.

*3) Vacuum pads are excluded from this 1 year warranty.

A vacuum pad is a consumable part, so it is warranted for a year after it is delivered.

Also, even within the warranty period, the wear of a product due to the use of the vacuum pad or failure due to the deterioration of rubber material are not covered by the limited warranty.

Compliance Requirements

When the product is exported, strictly follow the laws required by the Ministry of Economy, Trade and Industry (Foreign Exchange and Foreign Trade Control Law).

1. Procedure before operation/simple setting to use straight away

The controller is already set with the data of the actuator.

With the simple setting “easy mode”, it can be operated and running parameters can be changed easily.

1.1 Preparation

(1) Items to be prepared

Please check on the label, and the quantity of accessories, to confirm that it is the product that was ordered.

Table 1. Components

No.	Part name	Qty
(1)	Electric gripper	1
(2)	Controller	1
(3)	Power supply plug	1
(4)	Actuator cable	1
(5)	I/O cable (Not use in this section)	1
(6)	Teaching box	1
(7)	Controller setting kit [The controller setting software, The communication cable, USB cable and conversion unit are included.]	1

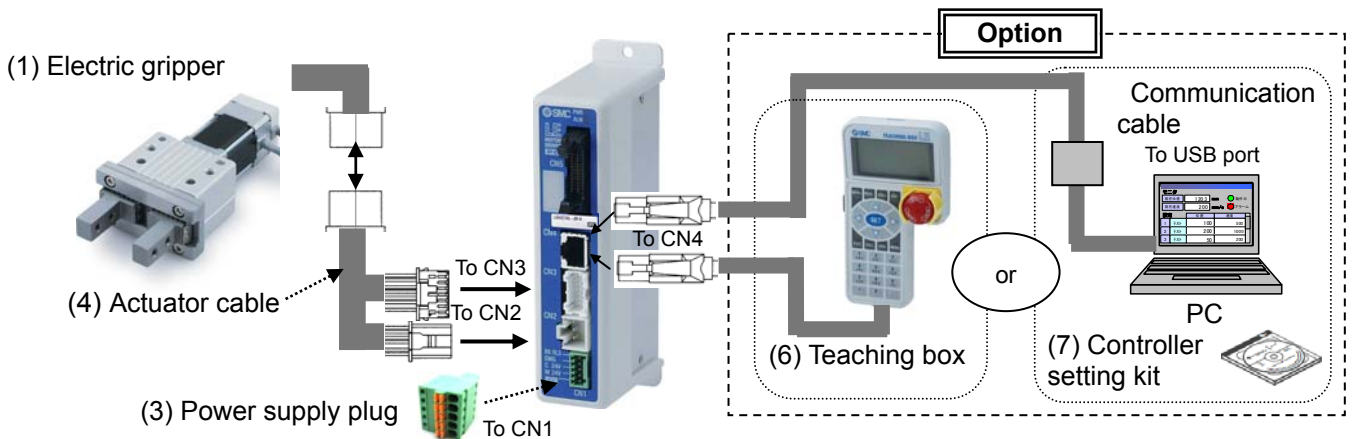

Table 2. Items to be prepared by the customer

Part name	Conditions
Power supply 24VDC Except “inrush-current restraining type”	Refer to power consumption of each actuator
Wire AWG20 (0.5mm ²)	Stripped wire length 8mm
Power supply plug Wiring	<p>Connect the plus side of DC 24V to the C24V, M24V and EMG terminals of the power supply plug, and the minus side to the 0V terminal.</p> <p>Push the open/ close lever and insert the wire into the electrical wire entry.</p> <p>Electrical wire entry</p>

1.2 Controller setting software version

(1) Installation of software

With the controller setting software CD-ROM, install the communication unit software, following the "Software Installation procedure" (PDF)

(2) Startup of software

, start up the ACT Controller setting software.

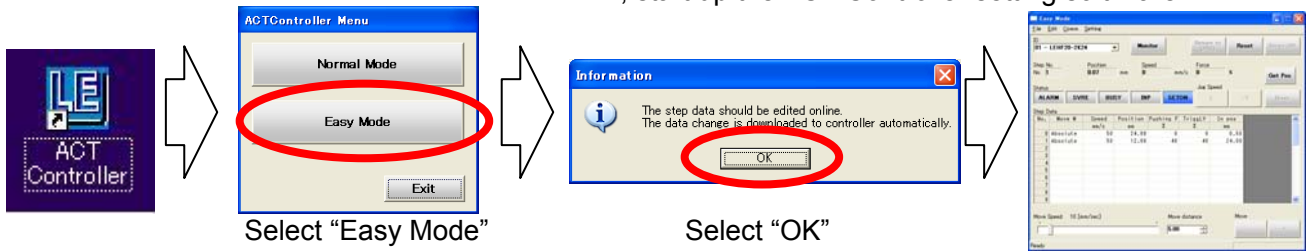

(3) JOG Drive

a. Driving preparation : Servo On → Return to ORIG

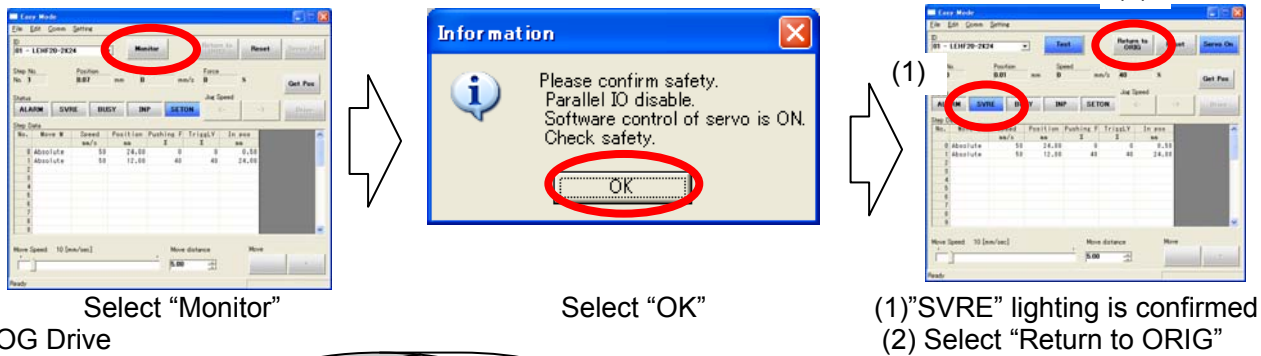

b. JOG Drive

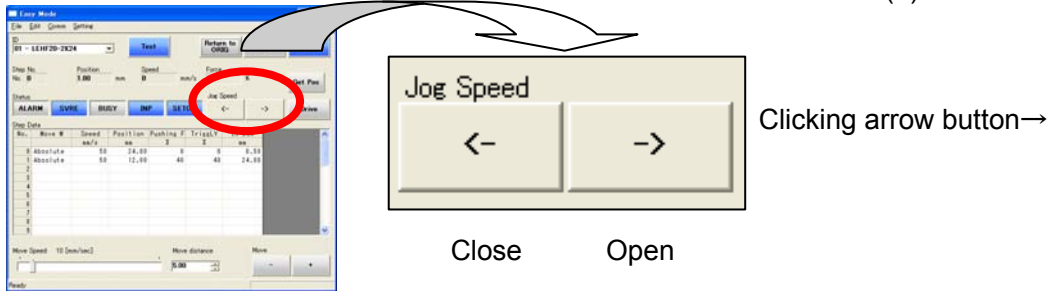

c. Driving stop : Servo Off

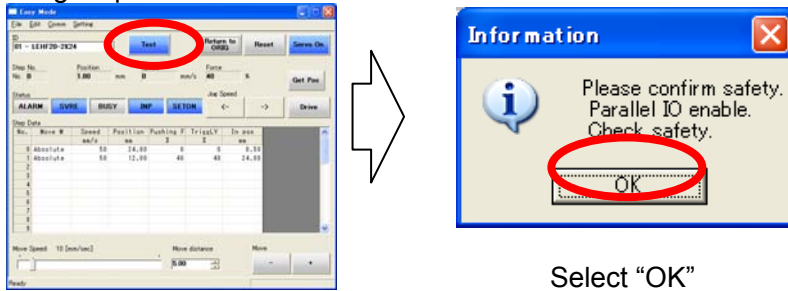

⚠ Caution

If an alarm is generated

(1) When "ALARM" is generated, release it by selecting (2) Reset.

In the case of an alarm code that cannot be released with "Reset", turn the power supply OFF and ON again. (1)

Note) For details of alarm codes, refer to the Controller Operation Manual.

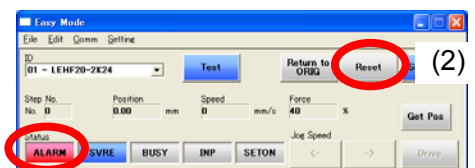

(4) TEST Drive / Step No.0 → No.1 → No.0...

a. Driving preparation : Servo On → Return to ORIG / Refer to “3.JOG Drive”.

b. TEST Drive

“Step No.0” Operation

Procedure 1:
Select “Step No.0”
You can select
anywhere in the row



Procedure 2:
Select “Drive” →

“Step No.1” Operation

Procedure 3:
Select “Step No.1”
You can select
anywhere in the row

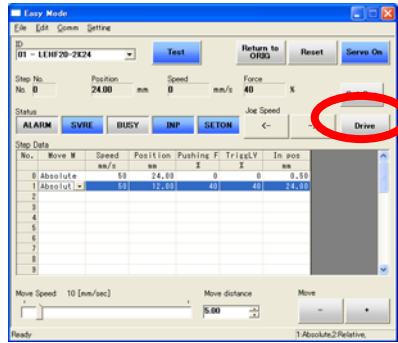

Procedure 4:
Select “Drive” →

c. Driving stop : Servo Off / Refer to “3.JOG Drive”.

(5) Step data change

Ex) “Step No.0” / Positioning operation

Step Data						
No.	Move M	Speed	Position	Pushing F	TriggLV	In pos
		mm/s	mm	%	%	mm
0	Absolute	50	24.00	0	0	0.50

Position: 24mm → 20mm

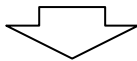

Input “20”

Step Data						
No.	Move M	Speed	Position	Pushing F	TriggLV	In pos
		mm/s	mm	%	%	mm
0	Absolute	50	20.00	0	0	0.50

Ex) “Step No.1” / Pushing operation / At the time of shipment, Step No. 1 is set to pushing operation

Step Data						
No.	Move M	Speed	Position	Pushing F	TriggLV	In pos
		mm/s	mm	%	%	mm
0	Absolute	50	20.00	0	0	0.50
1	Absolute	50	12.00	40	40	24.00

Position: 12mm → 5mm

Pushing force: 40% → 60%

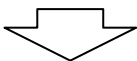

Input “5” Input “60”

Step Data						
No.	Move M	Speed	Position	Pushing F	TriggLV	In pos
		mm/s	mm	%	%	mm
0	Absolute	50	20.00	0	0	0.50
1	Absolute	50	5.00	60	40	24.00

For details of operation, and relationship between operation procedure and input/output signals, refer to “5.3 Step Data setting method” p. 27 to 35.

(6) Controller setting software screen explanation

Refer to the “Help / Easy mode” menu in the “ACT Controller” setting software.

1.3 Teaching box

(1) Name

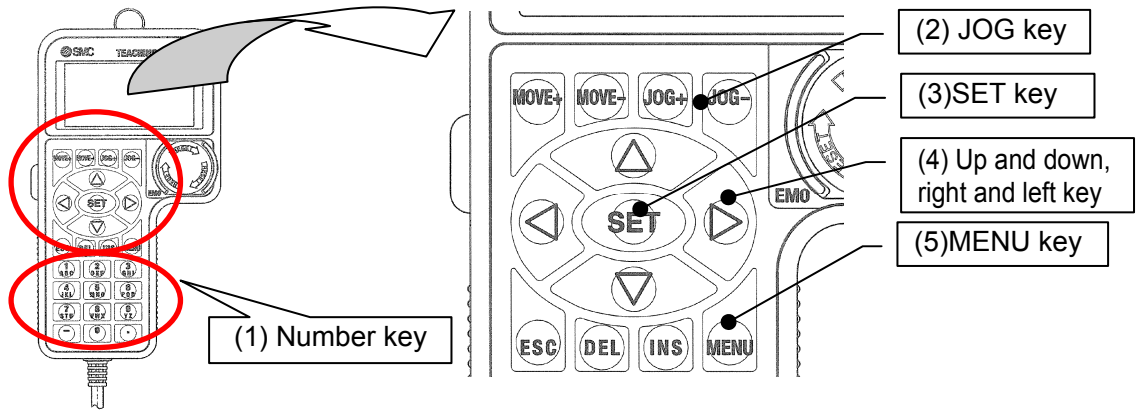

(2) JOG Drive

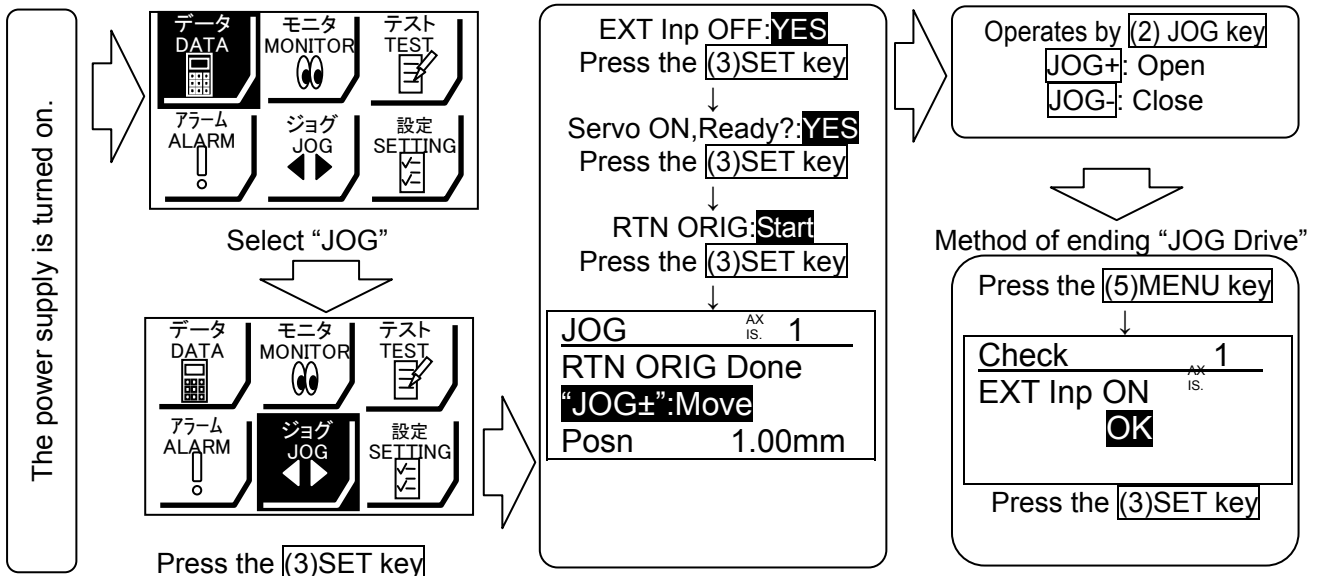

(3) TEST Drive / Step No.0 → No.1 → No.0...

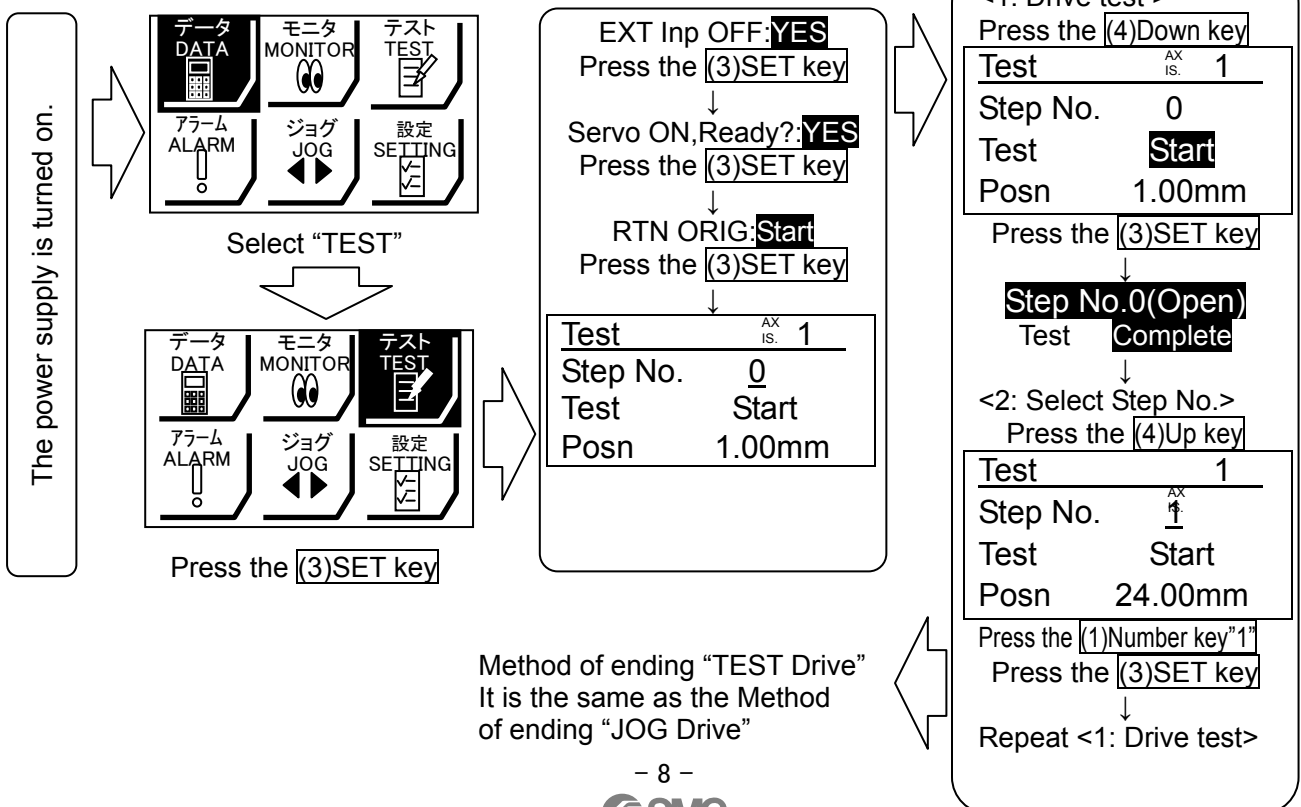

(4) Step data change

“Step No.0” / Positioning operation

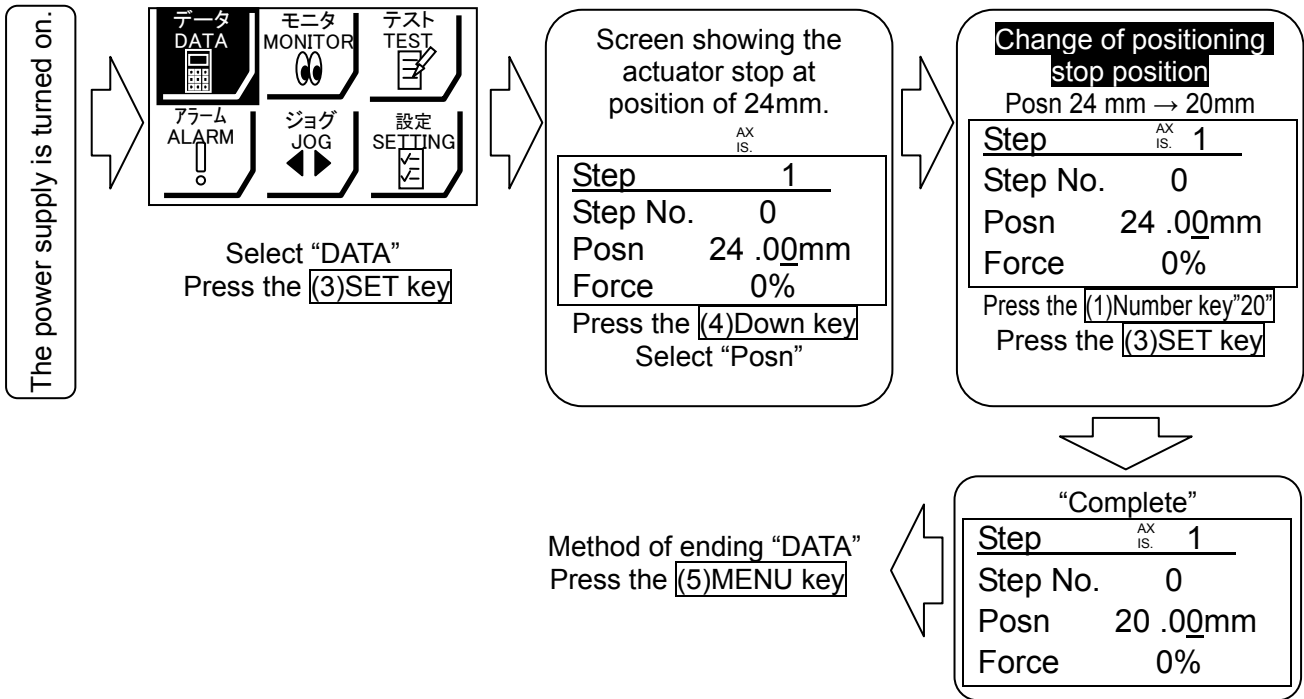

“Step No.1” / Pushing operation / At the time of shipment, Step No. 1 is set to pushing operation

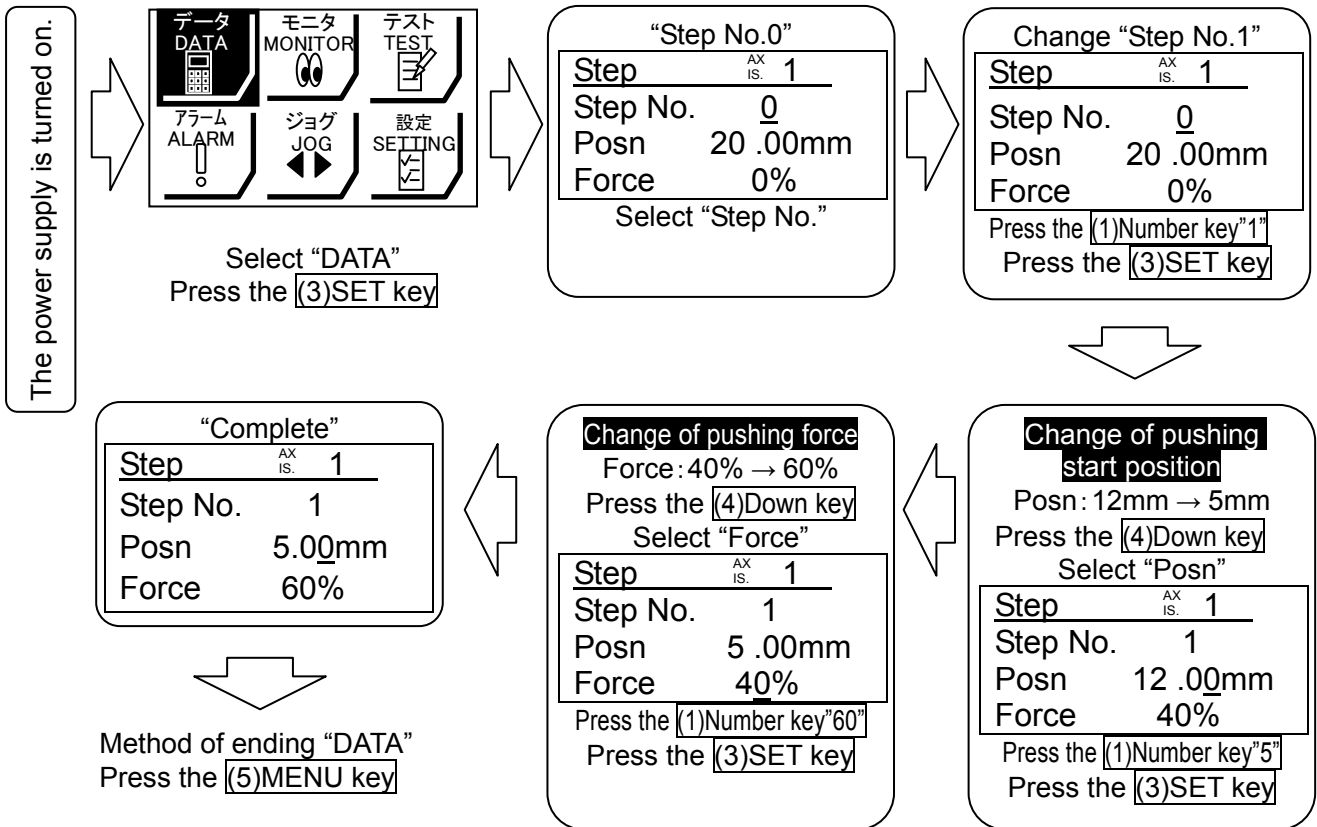

For details of operation, and relationship between operation procedure and input/output signals, refer to 5.3 “Step Data” setting method p. 27 to 35.

(5) Teaching box detailed explanation

Please refer to the teaching box manual.

2. Electric Gripper/LEHZ Series

2.1 LEHZ Series / Standard

2.1.1 Specification

Model		LEHZ10	LEHZ16	LEHZ20	LEHZ25	LEHZ32	LEHZ40	
Actuator specification	Stroke/both sides (mm)	4	6	10	14	22	30	
	Gripping force 40 to 100%(N) ^{Note 1)}	Basic	6 to 14		16 to 40		52 to 130	84 to 210
		Compact	2 to 6	3 to 8	11 to 28		-	-
	Opening/closing speed (mm/s) Gripping speed (mm/s) ^{Note 2)}	5 to 80 5 to 50		5 to 100 5 to 50		5 to 120 5 to 50		
	Drive method	Slide screw and Sliding cam						
	Finger guide type	Linear guide (No circulation)						
	Repeatability (mm) ^{Note 3)}	± 0.02						
	Repeated length determination accuracy (mm) ^{Note 4)}	± 0.05						
	Finger backlash: Both sides (mm) ^{Note 5)}	≤ 0.5				≤ 1.0		
	Impact resistance/vibration resistance (m/sec ²) ^{Note 6)}	150/30						
	Max. operating frequency(c.p.m)	60						
	Operating temperature range (°C)	5 to 40						
	Operating humidity range (%)	90 RH or less (No condensation)						
	Weight (g)	Basic	165	220	430	585	1120	1760
Compact		135	190	365	520	-	-	
Electric specification	Motor size	□20		□28		□42		
	Motor	Step motor (Servo 24VDC)						
	Encoder (Angular displacement sensor)	Incremental A/B phase (800 pulse/rotation)						
	Rated voltage(VDC)	24 ± 10%						
	Power consumption /Standby power consumption when operating(W) ^{Note 7)}	Basic	11/7		28/15		34/13	36/13
		Compact	8/7		22/12		-	-
	Moment max. power consumption(W) ^{Note 8)}	Basic	19		51		57	61
Compact		14		42		-	-	
Controller weight (g)	150 (Screw mounting type) 170 (DIN rail mounting type)							

Note 1) Gripping force should be from 10 to 20 times the weight of the object to be conveyed.

The force should be 150% when releasing the workpiece.

Gripping force accuracy should be +/-30% (F.S.) for LEHZ10/16 , +/-25% (F.S.) for LEHZ20/25
+/-20% (F.S.) for LEHZ32/40

Note 2) Gripping speed should be set in the range shown in the table as gripping speed during pushing operation.

Note 3) Repeatability means the variation of the gripping position (workpiece position) when the pushing operation is performed by the same sequence for the same workpiece.

Note 4) Repeated length determination accuracy means dispersion (value on the controller monitor) when the workpiece is repeatedly held in the same position.

Note 5) There will be no influence of backlash when gripping. Make the stroke longer for the amount of backlash when opening.

Note 6) Impact resistance: No malfunction occurred when the gripper was tested with a drop tester in both an axial direction and a perpendicular direction to the lead screw.

(The test was performed with the gripper in the initial state)

Vibration resistance: No malfunction occurred in a test ranging between 45 to 2000 Hz. Test was performed in both an axial direction and a perpendicular direction to the lead screw. (The test was performed with the gripper in the initial state)

Note 7) The "Standby power consumption when operating" (including the controller) is for when the actuator is stopped in the set position during the operation, include the electric power saving mode when gripping.

Note 8) The "Momentary max. power consumption" (including the controller) is for when the actuator is operating.

This value can be used for the selection of the power supply.

2.1.2 How to Order

LEHZ 10 □ K 2 — 4 □ □ — R 1 6N 1 □

● Size

10	Motor size	Nil	Basic
16		L (Note)	Compact
20			
25			
32			
40			

Note) Size: 10, 16, 20, 25 only

● Lead

K	Basic
---	-------

● Stroke(mm)

Stroke to both sides	Size
4	10
6	16
10	20
14	25
22	32
30	40

● Finger option

Nil	Basic type
A	Side tapped mounting
B	Through-hole in opening / closing direction
C	Flat type fingers

● Motor cable entry

Nil	Basic (Entry on the left side)
F	Entry on the front side

● Controller option

Nil	Screw mounting type
D	DIN rail mounting type

● I/O cable length(m)

Nil	Without cable
1	1.5
3	3
5	5

● Controller

Nil	Without controller
6N	With controller (NPN)
6P	With controller (PNP)
1N	With programless controller (NPN)
1P	With programless controller (PNP)

● Actuator cable length(m)

Nil	Without cable	8	8 *
1	1.5	A	10 *
3	3	B	15 *
5	5	C	20 *

*produced upon receipt of order.
(Only "Robotic type cables" can be selected.)

● Actuator cable

Nil	Without cable
R	Robotic type cables (Flexible type cables)
S	Standard cables

Finger option

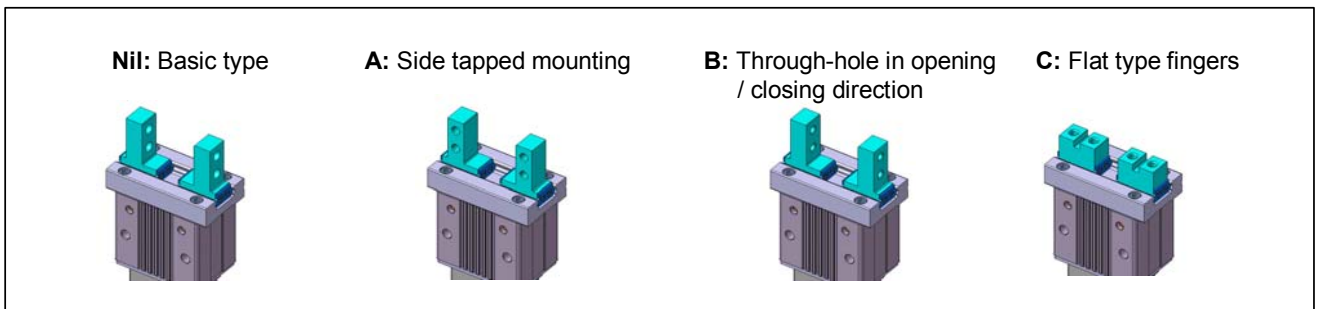

⚠ Caution

The actuator body and controller are sold as a package.

If When only the actuator is purchased separately, confirm that the combination of the controller, which you have and the actuator is compatible. / See 7.3 ⚠ Caution (1) on p. 42

<Be sure to check the following before use.>

- (1) Check that actuator label for model number.
This matches the controller.
- (2) Check Parallel I/O configuration matches (NPN or PNP).

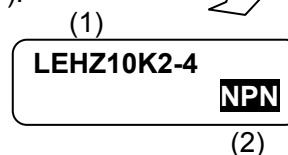

2.1.3 Construction

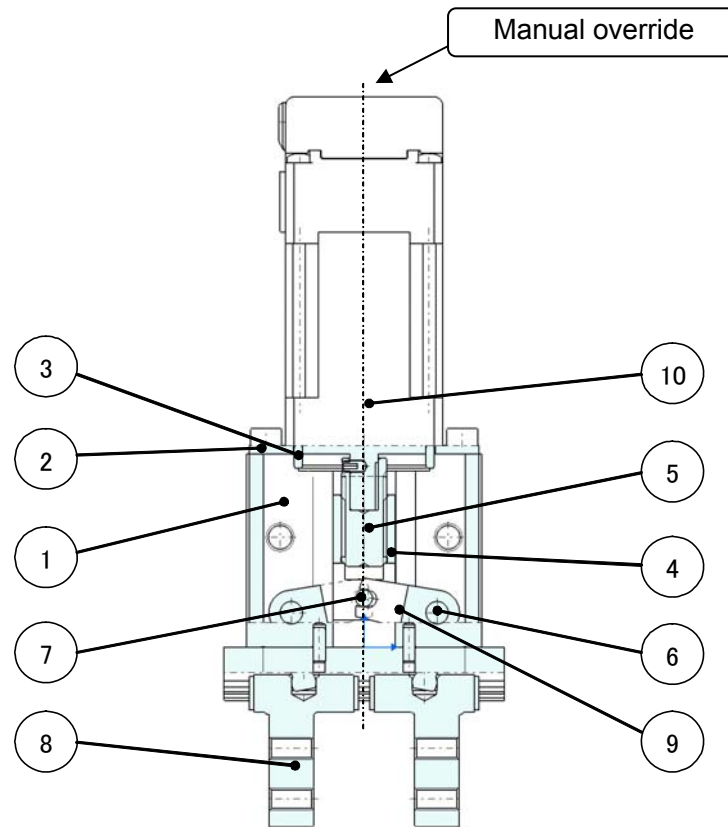

Parts list

No.	Part	Material	Remarks
1	Body	Aluminum alloy	Anodized
2	Motor plate	Aluminum alloy	Anodized
3	Guide ring	Aluminum alloy	
4	Slide nut	Stainless steel	Heat treated, Specially treated
5	Slide bolt	Stainless steel	Heat treated, Specially treated
6	Needle roller	High carbon chromium bearing steel	
7	Needle roller	High carbon chromium bearing steel	
8	Finger assembly	-	
9	Lever	Special stainless steel	
10	Step motor (Servo/24VDC)	-	

Spare parts ⑧ Finger assembly

Body size	Basic type	Side tap mounting	With thru hole in open and close direction	Flat finger
	No symbol	A	B	C
10	MHZ-A1002	MHZ-A1002-1	MHZ-A1002-2	MHZ-A1002-3
16	MHZ-A1602	MHZ-A1602-1	MHZ-A1602-2	MHZ-A1602-3
20	MHZ-A2002	MHZ-A2002-1	MHZ-A2002-2	MHZ-A2002-3
25	MHZ-A2502	MHZ-A2502-1	MHZ-A2502-2	MHZ-A2502-3
32	MHZ-A3202	MHZ-A3202-1	MHZ-A3202-2	MHZ-A3202-3
40	MHZ-A4002	MHZ-A4002-1	MHZ-A4002-2	MHZ-A4002-3

2.2 LEHZJ Series / With Dust Cover

2.2.1 Specification

Model		LEHZJ10	LEHZJ16	LEHZJ20	LEHZJ25
Stroke/both sides (mm)		4	6	10	14
Gripping force (N) ^{Note 1)}	Basic	6 to 14 (40 to 100%)		16 to 40 (40 to 100%)	
	Compact	3 to 6 (50 to 100%)	4 to 8 (50 to 100%)	11 to 28 (40 to 100%)	
Opening/closing speed (mm/s)		5 to 80		5 to 100	
Gripping speed (mm/s) ^{Note 2)}		5 to 50		5 to 50	
Drive method		Slide screw and Sliding cam			
Finger guide type		Linear guide (No circulation)			
Repeatability (mm) ^{Note 3)}		± 0.02			
Repeated length determination accuracy (mm) ^{Note 4)}		± 0.05			
Finger backlash: Both sides (mm) ^{Note 5)}		≤ 0.5			
Impact resistance/vibration resistance (m/sec ²) ^{Note 6)}		150/30			
Max. operating frequency(c.p.m)		60			
Operating temperature range (°C)		5 to 40			
Operating humidity range (%)		90 RH or less (No condensation)			
Weight (g)	Basic	170	230	440	610
	Compact	140	200	375	545
Motor size		□20		□28	
Motor		Step motor (Servo 24VDC)			
Encoder (Angular displacement sensor)		Incremental A/B phase (800 pulse/rotation)			
Rated voltage(VDC)		24 ± 10%			
Power consumption /Standby power consumption when operating(W) ^{Note 7)}	Basic	11/7		28/15	
	Compact	8/7		22/12	
Moment max. power consumption(W) ^{Note 8)}	Basic	19		51	
	Compact	14		42	
Controller weight (g)		150 (Screw mounting type) 170 (DIN rail mounting type)			

Note 1) Gripping force should be from 10 to 20 times the weight of the object to be conveyed.

The force should be 150% when releasing the workpiece.

Gripping force accuracy should be +/-30% (F.S.) for LEHZJ10/16 , +/-25% (F.S.) for LEHZJ20/25

Note 2) Gripping speed should be set in the range shown in the table as gripping speed during pushing operation.

Note 3) Repeatability means the variation of the gripping position (workpiece position) when the pushing operation is performed by the same sequence for the same workpiece.

Note 4) Repeated length determination accuracy means dispersion (value on the controller monitor) when the workpiece is repeatedly held in the same position.

Note 5) There will be no influence of backlash when gripping. Make the stroke longer for the amount of backlash when opening.

Note 6) Impact resistance: No malfunction occurred when the gripper was tested with a drop tester in both an axial direction and a perpendicular direction to the lead screw.

(The test was performed with the gripper in the initial state)

Vibration resistance: No malfunction occurred in a test ranging between 45 to 2000 Hz. Test was performed in both an axial direction and a perpendicular direction to the lead screw. (The test was performed with the gripper in the initial state)

Note 7) The "Standby power consumption when operating" (including the controller) is for when the actuator is stopped in the set position during the operation, include the electric power saving mode when gripping.

Note 8) The "Momentary max. power consumption" (including the controller) is for when the actuator is operating.

This value can be used for the selection of the power supply.

2.2.2 How to Order

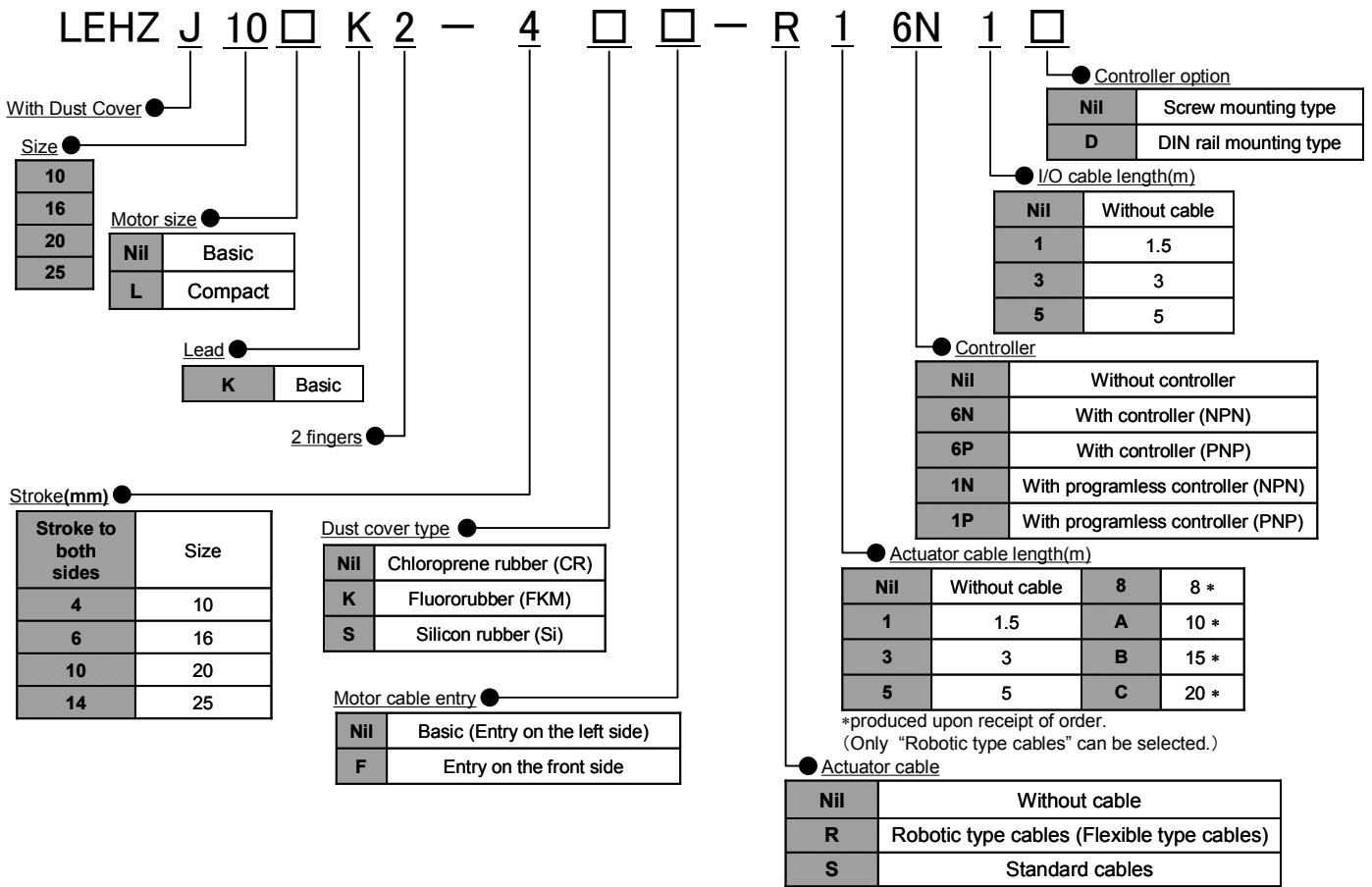

Caution

The actuator body and controller are sold as a package.

If When only the actuator is purchased separately, confirm that the combination of the controller, which you have and the actuator is compatible. / See 7.3  Caution (1) on p. 42

<Be sure to check the following before use.>

- (1) Check that actuator label for model number.
This matches the controller.
- (2) Check Parallel I/O configuration matches (NPN or PNP).

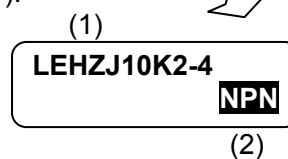

2.2.3 Construction

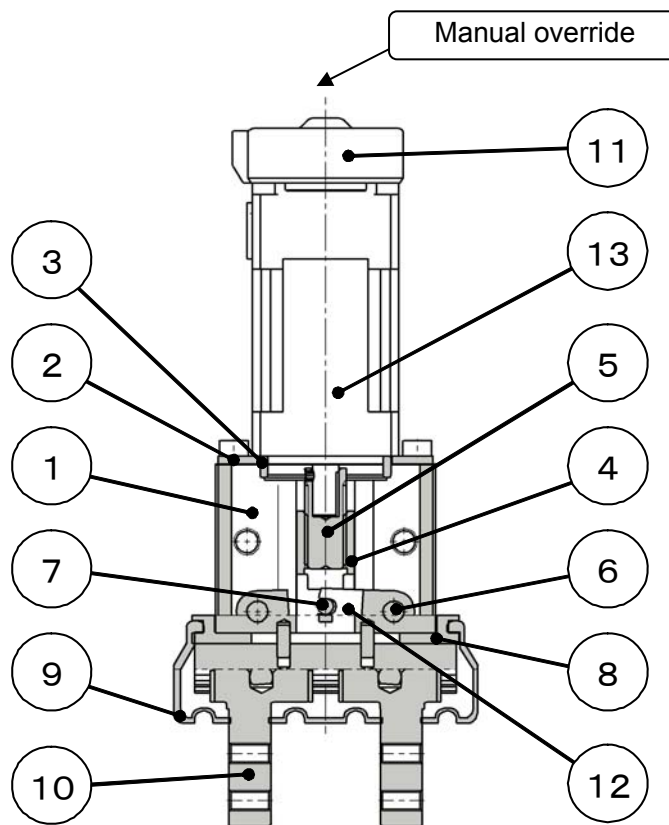

Parts list

No.	Part	Material	Remarks
1	Body	Aluminum alloy	Anodized
2	Motor plate	Aluminum alloy	Anodized
3	Guide ring	Aluminum alloy	
4	Slide nut	Stainless steel	Heat treated, Specially treated
5	Slide bolt	Stainless steel	Heat treated, Specially treated
6	Needle roller	High carbon chromium bearing steel	
7	Needle roller	High carbon chromium bearing steel	
8	Body plate	Aluminum alloy	Anodized
9	Dust cover	CR	Chloroprene rubber
		FKM	Fluororubber
		Si	Silicon rubber
10	Finger assembly	-	
11	Encoder dust cover	Si	Silicon rubber
12	Lever	Special stainless steel	
13	Step motor (Servo/24VDC)	-	

Spare parts

No.	Part		LEHZJ10	LEHZJ16	LEHZJ20	LEHZJ25	
9	Dust cover	Material	CR	MHZJ2-J10	MHZJ2-J16	MHZJ2-J20	MHZJ2-J25
		FKM	MHZJ2-J10F	MHZJ2-J16F	MHZJ2-J20F	MHZJ2-J25F	
		Si	MHZJ2-J10S	MHZJ2-J16S	MHZJ2-J20S	MHZJ2-J25S	
10	Finger assembly		MHZJ-A1002	MHZJ-A1602	MHZJ-A2002	MHZJ-A2502	

*Dust cover of the gripper finger is consumables. Replace it newly as necessary.

/ See 8.4⚠Caution (1) on p. 53

2.2.4 Protection seal to prevent ingress of dust

When using the LEHZJ series, please affix the "protection seal to prevent ingress of dust" provided. Otherwise machining chips and fine particles may get into the product from the outside, leading to operation failure.

* This is equivalent to IP50 (dust-proof). Please note that it does not provide a drip-proof function.

< Protection seal to prevent ingress of dust >

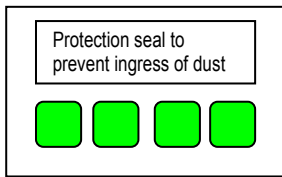

Please remove dust, oil etc. and affix the "protection seal to prevent ingress of dust "

< Sticking position >

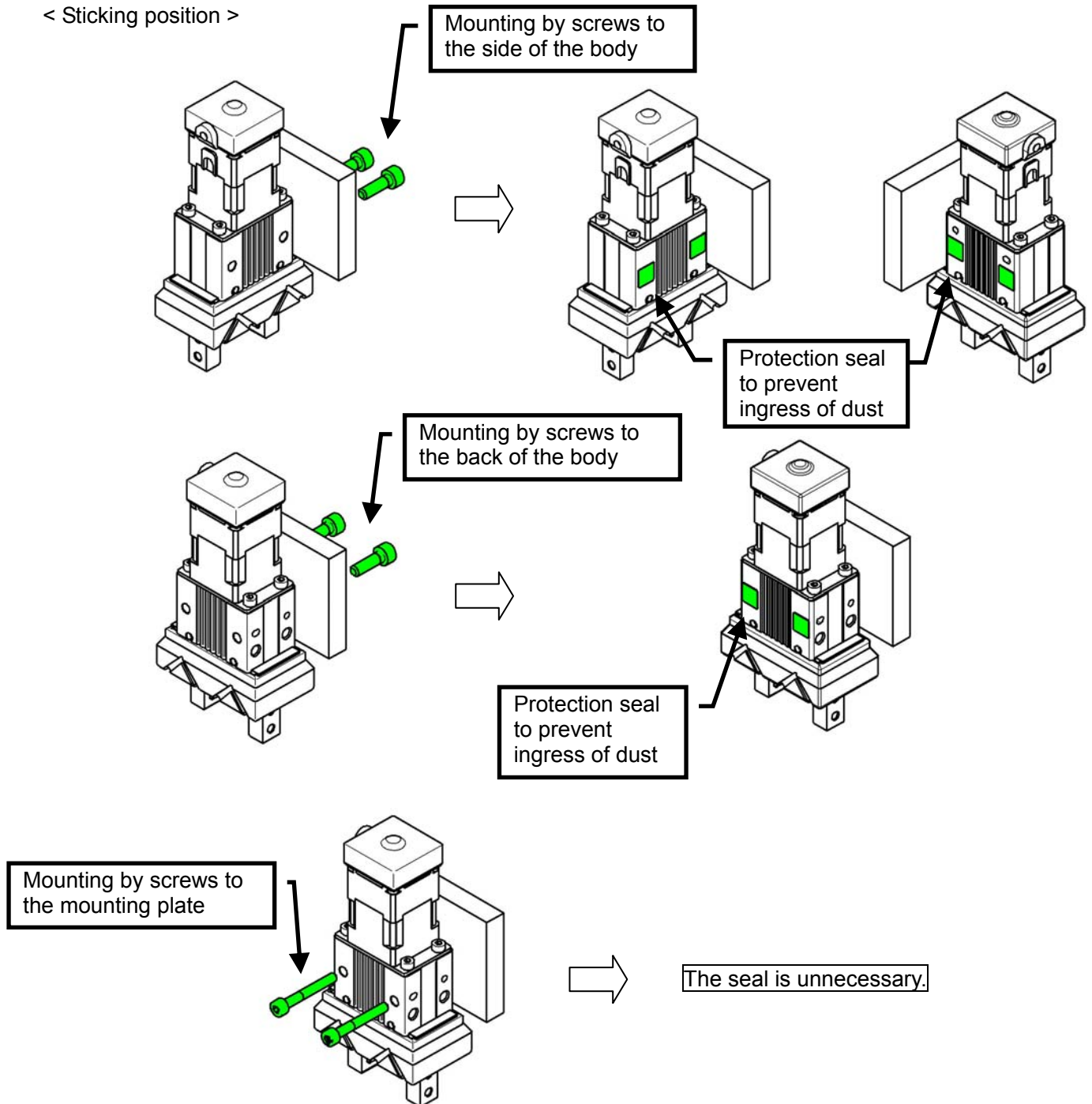

3. Electric Gripper/LEHF Series

3.1 Specification

Model		LEHF10	LEHF20	LEHF32	LEHF40	
Actuator specification	Stroke/both sides (mm)	Basic	16	24	32	40
		long st.	32	48	64	80
	Gripping force 40 to 100%(N) ^{Note 1)}		3 to 7	11 to 28	48 to 120	72 to 180
	Opening/closing speed (mm/s) ^{Note 2)}		5 to 80	5 to 100		
	Gripping speed (mm/s) ^{Note 2)}		5 to 20	5 to 30		
	Drive method		Sliding screw and Belt bending			
	Finger guide type		Linear guide (No circulation)			
	Repeatability (mm) ^{Note 3)}		± 0.05			
	Repeated length determination accuracy (mm) ^{Note 4)}		± 0.05			
	Finger backlash: Both sides (mm) ^{Note 5)}		≤ 1.0			
	Impact resistance/vibration resistance (m/sec ²) ^{Note 6)}		150/30			
	Max. operating frequency(c.p.m)		60			
	Operating temperature range (°C)		5 to 40			
	Operating humidity range (%)		90 RH or less (No condensation)			
	Weight (g)	Basic	340	610	1625	1980
long st.		370	750	1970	2500	
Electric specification	Motor size		□20	□28	□42	
	Motor		Step motor (Servo 24VDC)			
	Encoder (Angular displacement sensor)		Incremental A/B phase (800 pulse/rotation)			
	Rated voltage(VDC)		24 ± 10%			
	Power consumption /Standby power consumption when operating(W) ^{Note 7)}		11/7	28/15	34/13	36/13
	Moment max. power consumption(W) ^{Note 8)}		19	51	57	61
	Controller weight (g)		150 (Screw mounting type) 170 (DIN rail mounting type)			

Note 1) Gripping force should be from 10 to 20 times of the weight of the object to be conveyed.

The force should be 150% when releasing the workpiece.

Gripping force accuracy should be +/-30% (F.S.) for LEHF10 +/-25% (F.S.) for LEHF20
+/-20% (F.S.) for LEHF32/40

Note 2) Gripping speed should be set in the range shown in the table as gripping speed during pushing operation.

Note 3) Repeatability means the variation of the gripping position (workpiece position) when the pushing operation is performed by the same sequence for the same workpiece.

Note 4) Repeated length determination accuracy means dispersion (value on the controller monitor) when the workpiece is repeatedly held in the same position.

Note 5) There will be no influence of backlash when gripping. Make the stroke longer for the amount of backlash when opening.

Note 6) Impact resistance: No malfunction occurred when the gripper was tested with a drop tester in both an axial direction and a perpendicular direction to the lead screw.

(The test was performed with the gripper in the initial state)

Vibration resistance: No malfunction occurred in a test ranging between 45 to 2000 Hz. Test was performed in both an axial direction and a perpendicular direction to the lead screw. (The test was performed with the gripper in the initial state)

Note 7) The "Standby power consumption when operating" (including the controller) is for when the actuator is stopped in the set position during the operation, include the electric power saving mode when gripping.

Note 8) The "Momentary max. power consumption" (including the controller) is for when the actuator is operating.

This value can be used for the selection of the power supply.

3.2 How to Order

LEHF 10 K 2 - 16 □ - R 1 6N 1 □

● Size

10
20
32
40

● 2 fingers

● Lead

K	Basic
---	-------

● Stroke(mm)

Stroke to both sides		Size
Basic	Long	
16	32	10
24	48	20
32	64	32
40	80	40

● Motor cable entry

Nil	Basic (Entry on the right side)
L	Entry on the left side

● Controller option

Nil	Screw mounting type
D	DIN rail mounting type

● I/O cable length(m)

Nil	Without cable
1	1.5
3	3
5	5

● Controller

Nil	Without controller
6N	With controller (NPN)
6P	With controller (PNP)
1N	With programless controller (NPN)
1P	With programless controller (PNP)

● Actuator cable length(m)

Nil	Without cable	8	8 *
1	1.5	A	10 *
3	3	B	15 *
5	5	C	20 *

*produced upon receipt of order.
(Only "Robotic type cables" can be selected.)

● Actuator cable

Nil	Without cable
R	Robotic type cables (Flexible type cables)
S	Standard cables

⚠ Caution

The actuator body and controller are sold as a package.

If When only the actuator is purchased separately, confirm that the combination of the controller, which you have and the actuator is compatible. / See 7.3 ⚠ Caution (1) on p. 42

<Be sure to check the following before use.>

- (1) Check that actuator label for model number.
This matches the controller.
- (2) Check Parallel I/O configuration matches (NPN or PNP).

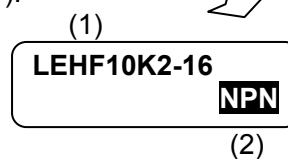

3.3 Construction

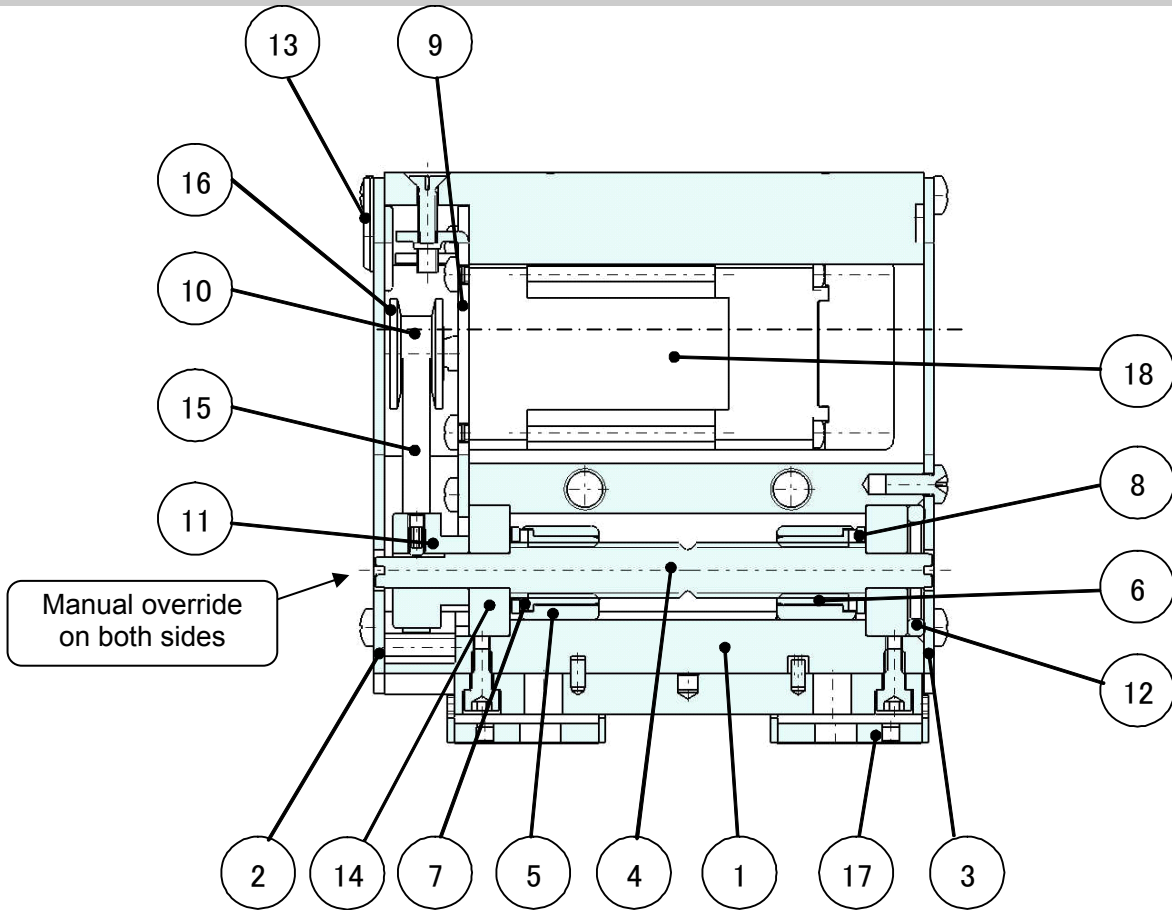

Parts list

No.	Part	Material	Remarks
1	Body	Aluminum alloy	Anodized
2	Side plate A	Aluminum alloy	Anodized
3	Side plate B	Aluminum alloy	Anodized
4	Slide shaft	Stainless steel	Heat treated, Specially treated
5	Slide bush	Stainless steel	
6	Slide nut	Stainless steel	Heat treated, Specially treated
7	Slide nut	Stainless steel	Heat treated, Specially treated
8	Fixed plate	Stainless steel	
9	Motor plate	Carbon steel	
10	Pulley A	Aluminum alloy	
11	Pulley B	Aluminum alloy	
12	Bearing holder	Aluminum alloy	
13	Rubber bush	NBR	
14	Bearing	-	
15	Belt	-	
16	Flange	-	
17	Finger assembly	-	
18	Step motor (Servo/24VDC)	-	

4. Electric Gripper/LEHS Series

4.1 Specification

Model		LEHS10	LEHS20	LEHS32	LEHS40
Stroke/dia.(mm)		4	6	8	12
Gripping force 40 to 100%(N) ^{Note 1)}	Basic	2.2 to 5.5	9 to 22	36 to 90	52 to 130
	Compact	1.4 to 3.5	7 to 17	-	-
Opening/closing speed (mm/s)		5 to 70	5 to 80	5 to 100	5 to 120
Gripping speed (mm/s) ^{Note 2)}		5 to 50	5 to 50	5 to 50	5 to 50
Drive method		Sliding screw and Wedge cam			
Repeatability (mm) ^{Note 3)}		± 0.02			
Repeated length determination accuracy (mm) ^{Note 4)}		± 0.05			
Finger backlash: Both sides (mm) ^{Note 5)}		≤ 0.5			
Impact resistance/vibration resistance (m/sec ²) ^{Note 6)}		150/30			
Max. operating frequency(c.p.m)		60			
Operating temperature range (°C)		5 to 40			
Operating humidity range (%)		90 RH or less (No condensation)			
Weight (g)	Basic	185	410	975	1265
	Compact	150	345	-	-
Motor size		□20	□28	□42	
Motor		Step motor (Servo 24VDC)			
Encoder (Angular displacement sensor)		Incremental A/B phase (800 pulse/rotation)			
Rated voltage(VDC)		24 ± 10%			
Power consumption /Standby power consumption when operating(W) ^{Note 7)}	Basic	11/7	28/15	34/13	36/13
	Compact	8/7	22/12	-	-
Moment max. power consumption (W) ^{Note 8)}	Basic	19	51	57	61
	Compact	14	42	-	-
Controller weight (g)		150 (Screw mounting type) 170 (DIN rail mounting type)			

Note 1) Gripping force should be from 7 to 13 times of the weight of the object to be conveyed.

The force should be 150% when releasing the workpiece.

Gripping force accuracy should be +/-30% (F.S.) for LEHS10 , +/-25% (F.S.) for LEHS20
+/-20% (F.S.) for LEHS32/40

Note 2) Gripping speed should be set in the range shown in the table as gripping speed during pushing operation.

Note 3) Repeatability means the variation of the gripping position (workpiece position) when the pushing operation is performed by the same sequence for the same workpiece.

Note 4) Repeated length determination accuracy means dispersion (value on the controller monitor) when the workpiece is repeatedly held in the same position.

Note 5) There will be no influence of backlash when gripping. Make the stroke longer for the amount of backlash when opening.

Note 6) Impact resistance: No malfunction occurred when the gripper was tested with a drop tester in both an axial direction and a perpendicular direction to the lead screw.

(The test was performed with the gripper in the initial state)

Vibration resistance: No malfunction occurred in a test ranging between 45 to 2000 Hz. Test was performed in both an axial direction and a perpendicular direction to the lead screw. (The test was performed with the gripper in the initial state)

Note 7) The "Standby power consumption when operating" (including the controller) is for when the actuator is stopped in the set position during the operation, include the electric power saving mode when gripping.

Note 8) The "Momentary max. power consumption" (including the controller) is for when the actuator is operating.

This value can be used for the selection of the power supply.

4.2 How to Order

LEHS 10 □ K 3 — 16 □ — R 1 6N 1 □

● Size

10
20
32
40

● 3 fingers

● Motor size

Nil	Basic
L (Note)	Compact

Note) Size: 10, 20 only

● Lead

K	Basic
---	-------

● Stroke(mm)

Stroke to dia.	Size
4	10
6	20
8	32
12	40

● Motor cable entry

Nil	Basic (Entry on the left side)
F	Entry on the front side
R	Entry on the right side

● Controller option

Nil	Screw mounting type
D	DIN rail mounting type

● I/O cable length(m)

Nil	Without cable
1	1.5
3	3
5	5

● Controller

Nil	Without controller
6N	With controller (NPN)
6P	With controller (PNP)
1N	With programless controller (NPN)
1P	With programless controller (PNP)

● Actuator cable length(m)

Nil	Without cable	8	8 *
1	1.5	A	10 *
3	3	B	15 *
5	5	C	20 *

*produced upon receipt of order.
(Only "Robotic type cables" can be selected.)

● Actuator cable

Nil	Without cable
R	Robotic type cables (Flexible type cables)
S	Standard cables

Caution

The actuator body and controller are sold as a package.

If When only the actuator is purchased separately, confirm that the combination of the controller, which you have and the actuator is compatible. / See 7.3  Caution (1) on p. 42

<Be sure to check the following before use.>

- (1) Check that actuator label for model number.
This matches the controller.
- (2) Check Parallel I/O configuration matches (NPN or PNP).

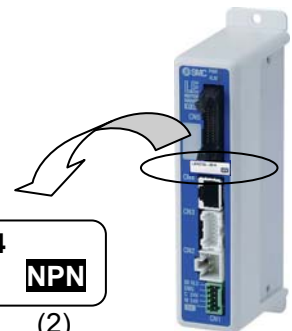
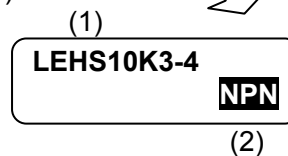

4.3 Construction

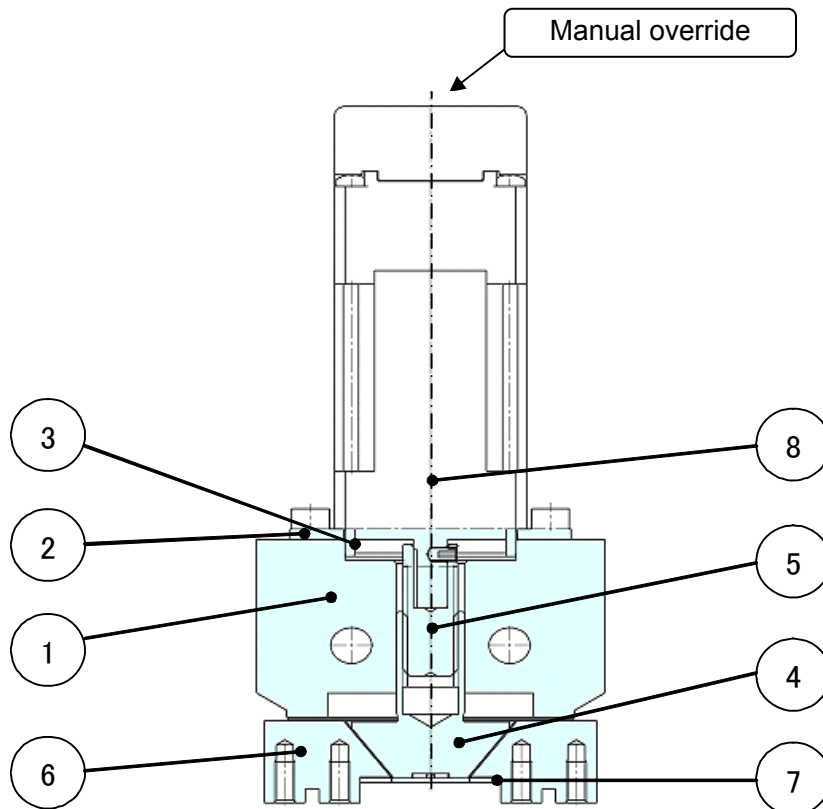

Parts list

No.	Part	Material	Remarks
1	Body	Aluminum alloy	Anodized
2	Motor plate	Aluminum alloy	Anodized
3	Guide ring	Aluminum alloy	
4	Slide cam	Stainless steel	Heat treated, Specially treated
5	Slide bolt	Stainless steel	Heat treated, Specially treated
6	Finger	Carbon steel	Heat treated, Specially treated
7	End plate	Stainless steel	
8	Step motor (Servo/24VDC)	-	

5. Product Outline

5.1 System construction

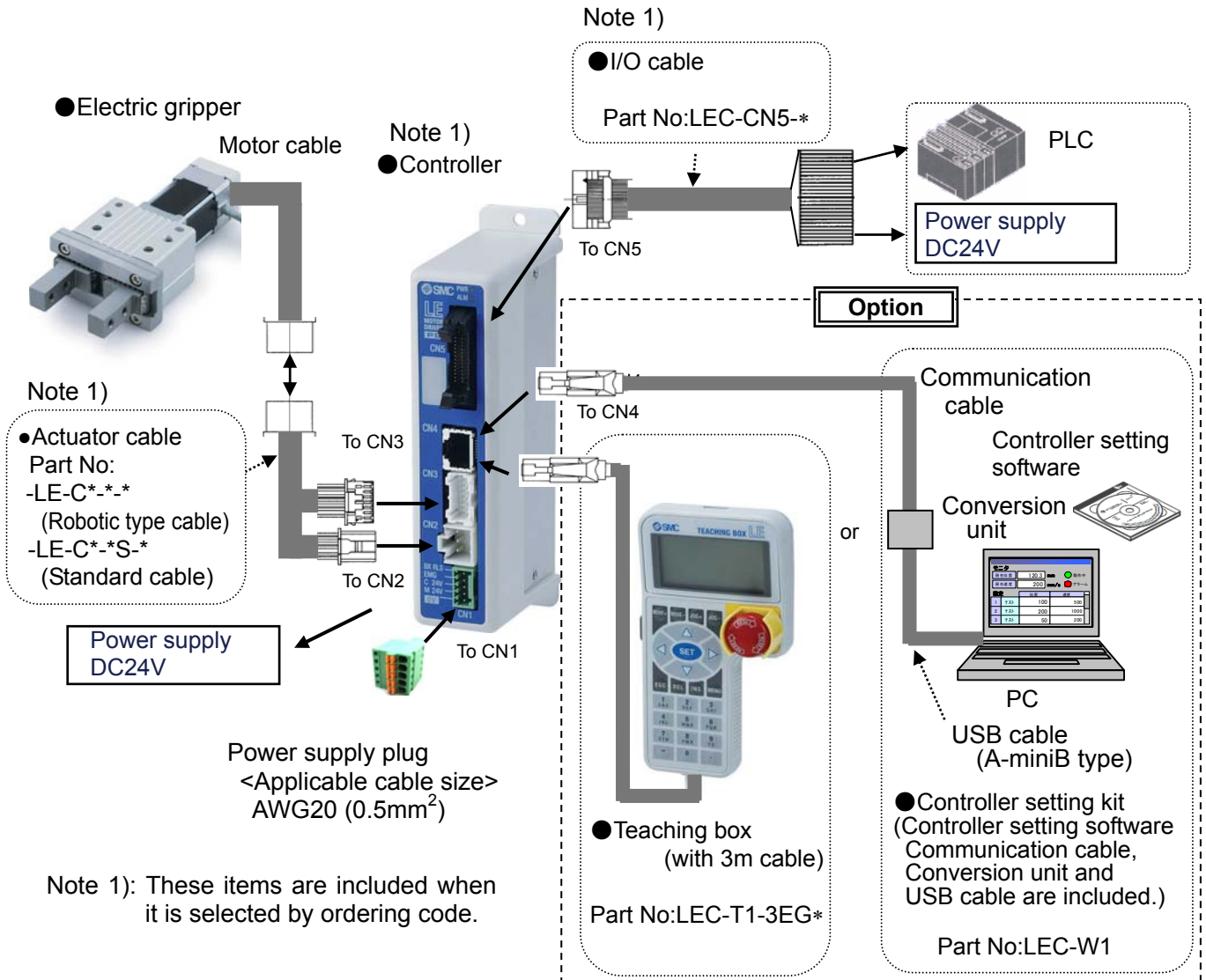

Warning

Refer to the operation manual of the LEC (controller) for detailed wiring.

/See 6 Wiring of cables on p.39.

Communication cable is to be connected to PC by USB cable through conversion unit.

And do not connect teaching box to PC.

Use only specified cables otherwise there maybe fire risk and damage.

The actuator body and controller are sold as a package.

If When only the actuator is purchased seperately, confirm that the combination of the controller, which you have and the actuator is compatible.

/ See 7.3 Caution (1) on p. 42

<Be sure to check the following before use.>

- (1) Check that actuator label for model number. This matches the controller.
- (2) Check Parallel I/O configuration matches (NPN or PNP).

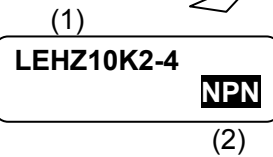

5.2 Setting Function

Refer to the operation manual of the controller (LEC series) for details of the setting function.

Easy Mode for simple setting

>Select "Easy mode" for instant operation

Controller setting software

- Setting and operation, such as the step data setting, test drive and JOG / fixed-distance moving, can be performed on the same page.

Speed setting of JOG / fixed distance

JOG moving

Start testing

Positioning data setting

Fixed distance moving

Teaching box

- Setting and operation by the simple screen without scrolling.
- Select function by the iconized menu at the first page.
- Step data setting and monitoring at the second page.

1st screen

2nd screen

Data	Axis 1
Step No.	0
Posn	123.45mm
Force	30%

It can be registered by "SET" after entering the values.

Example of setting the step data

1st screen

2nd screen

Monitor	Axis 1
Step No.	1
Posn	12.34mm
Force	50%

Operation status can be checked

Example of checking the operation status

Normal mode for the detailed setting

>Select “Normal mode” if the detailed setting are necessary.

- Step data can be set in detail.
- Parameters can be set.
- Signals and terminal condition can be monitored.
- JOG and fixed distance movement, return to origin position, test operation and testing of compulsory output can be done.

Controller setting soft ware

- Every function, step data, parameter, monitor and teaching are indicated in a different window.

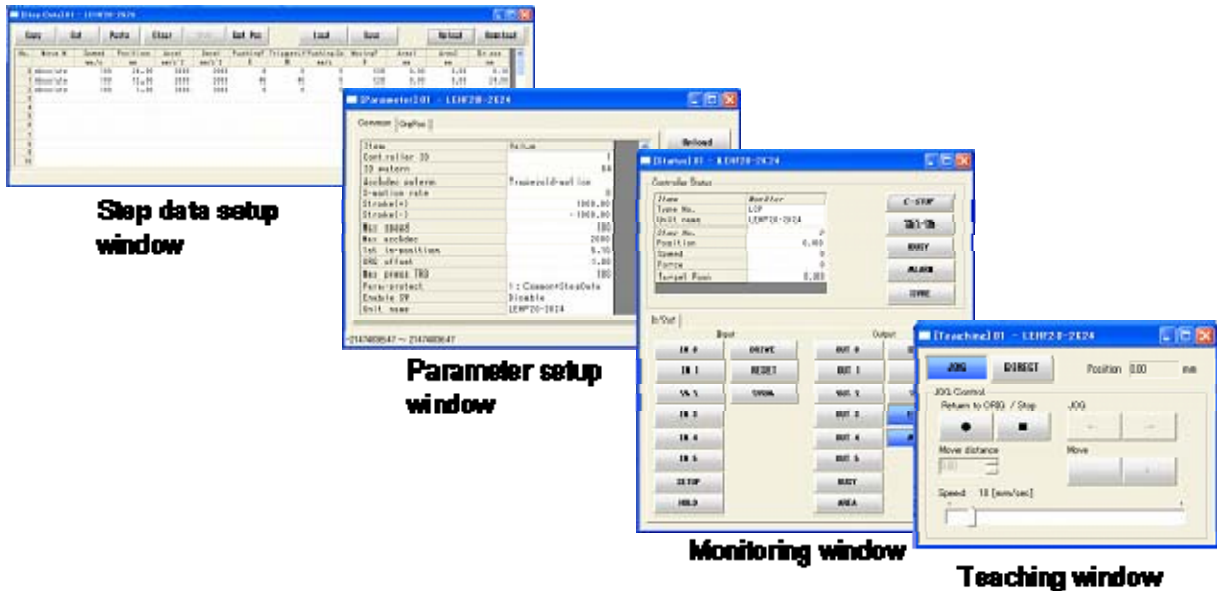

Teaching box

- The data in the controller can be saved / forwarded in this teaching box.
- Continuous test operation can be made after specifying five step data.

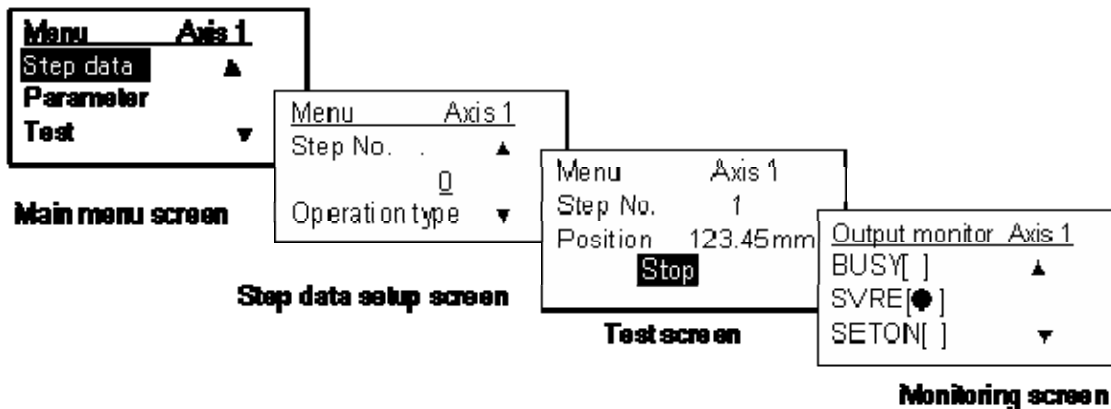

Controlled items

PC: Controller setting software
 TB: Teaching box
 O: Available function
 X: Not available function

Function		Content	Easy Mode		Normal mode
			PC	TB	PC/TB
Step data	Movement method	Can be selected of absolute/relative position move	O	X	O
	Speed	Can be set in units of 1mm/s. It is the speed between the fingers.	O	O	O
	Position	Can be set in units of 0.01mm. It is the position between the fingers (when pushing: pushing starting position)	O	O	O
	Acceleration Deceleration	Can be set in units of 1mm/s ² . It is the Acc/Dec between the fingers.	O	O	O
	Pushing force	Can be set in units of 1% from 40% to 100%. Positioning operation: Set to 0%.	O	O	O
	Trigger LV	Trigger LV of target force when pushing operation: Can be set in units of 1% from 40% to 100%.	O	X	O
	Pushing speed	Can be set in units of 1mm/s. It is the pushing speed between the fingers.	O	X	O
	Moving force	Can be set in units of 1% from 40% to 150%. Moving force should be set to 150% when detaching.	O	X	O
	Area output	Can be set in units of 0.01mm. It is the position between the fingers.	O	X	O
	In position	During positioning operation: Width to the target position. It should be set to 0.5 or more. During pushing operation: How much it moves during pushing	O	X	O
Parameter (Except)	Stroke(+)	+ side limit of position. (Can be set in units of 0.01mm.)	X	X	O
	Stroke(-)	- side limit of position. (Can be set in units of 0.01mm.)	X	X	O
	ORIG direction	Direction of the return to the original position can be set	X	X	O
	ORIG speed	Speed when returning to the original position can be set.	X	X	O
	ORIG ACC	Acceleration when returning to origin can be set.	X	X	O
Test	JOG	It can make continuous operation at the set speed while the switch is being pressed.	O	O	O
	MOVE	It can make test operation at the set distance and speed from the current position when the switch is pressed.	O	X	O
	Return to ORIG	Test of return to origin can be done.	O	O	O
	Test drive	The operation of the specified step data can be tested.	O	O	O (Continuous operation)
	Force output	ON/OFF of the output terminal can be tested.	X	X	O
Monitor	DRV mon	Current position, current speed, current force and the specified step data No. can be monitored.	O	O	O
	In/Out mon	Current ON/OFF status of the input and output terminal can be monitored.	X	X	O
ALM	Status	The alarm currently being generated can be confirmed, and be reset.	O	O	O
	ALM Log record	The alarm generated in the past can be confirmed.	X	X	O
File	Save・Load	The step data and parameter of the objective controller can be saved, forwarded and deleted.	X	X	O
Others	Language	language can be changed to Japanese/English.	O *3	O *2	O *2*3

*1 Every parameter is set to the recommended condition before shipment from the factory. Only change the setting of the items which require adjustment.

*2 Teaching box: In the Normal mode the teaching box can be set to work in English or Japanese.

*3 Controller setting software: Can be installed by selecting English version or Japanese version.

5.3 Step data setting method

Refer to the operation manual of the controller (LEC series) for details.

This operation manual specifies the electric gripper, if an actuator other than the electric gripper is used, refer to the operation manual of each type of actuator and controller (LEC series) regarding the description of step data.

Caution

The actuator body and controller are sold as a package.

If When only the actuator is purchased separately, confirm that the combination of the controller, which you have and the actuator is compatible. / See 7.3  Caution (1) on p. 42

<Be sure to check the following before use.>

- (1) Check that actuator label for model number.
This matches the controller.
- (2) Check Parallel I/O configuration matches (NPN or PNP).

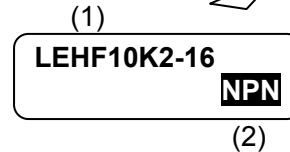

Positioning operation

In the positioning operation, the electric gripper moves to and stops at the target position.
The following image shows the setting items and operation.

<Confirmation of reaching the target position during the positioning operation>

When the fingers of the gripper reaches the range of the target position, the target position reaching signal 【INP】 (in position) is outputted.

When the table of actuator enters the range of 【in position】, the INP output signal turns on.

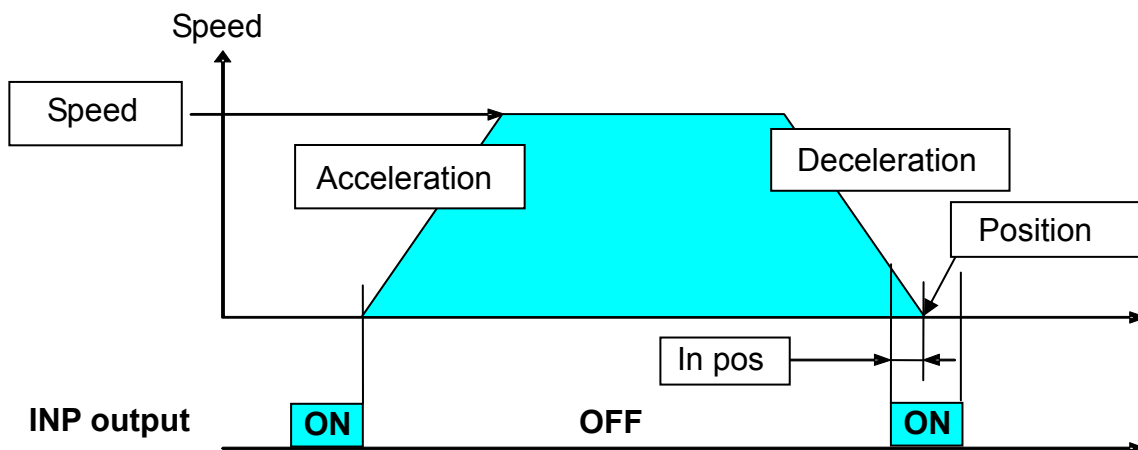

Caution

When the gripper is required to grip a work piece, use it in “pushing operation”.

If it is used as “positioning operation”, it can cause an error such as galling whilst it is gripping a workpiece.

Note) Use the manual override to open and close the fingers when the fingers have been galling.

/ See 8.3  Caution (2) on p. 49 and Caution (8) on p. 51

<Items and set values in positioning operation>

Step No. 0: Positioning operation

No.	Move M	Speed	Position	Accel	Decel	PushingF	TriggerLV	PushingSp	MovingF	Area1	Area2	In pos
		mm/s	mm	mm/s ²	mm/s ²	%	%	mm/s	%	mm	mm	mm
0	Absolute	120	22.00	2000	2000	0	0	5	150	20.00	22.00	10.00
1	Absolute	80	5.00	2000	2000	100	100	5	150	4.00	5.00	4.00

【◎】 Need to be set · 【○】 Need to be adjusted as required

【X】 Not used. Items don't need to be changed in positioning operation.

a <◎ Movement MOD> When the absolute position is required, set Absolute
When the relative position is required, set Relative
⇒ Absolute: Distance from the origin position. / General setting method
Relative: Feed from the current position. / This is used when simplified data.

b <◎ Speed> Transfer speed to the target position. ⇒ It is the speed between both fingers.

c <◎ Position> Target position. ⇒ It is the width between both fingers.
Note) For the intended purpose of electric gripper, add margin of backlash in case of set position is at fully closed finger position. /See 8.3⚠Caution (4) on p. 50

d <○ Acceleration> The parameter which defines how rapidly the actuator reaches the speed set in **b**.
The higher the set value, the faster it reaches the speed set in **b**.

e <○ Deceleration> The parameter which defines how rapidly the actuator comes to stop.
The higher the set value, the quicker it stops.

f <◎ Pushing force> Set (If values other than 0 set, the operation will be changed to the pushing operation.)

g <X Trigger LV> **h** <X Pushing speed>

i <○ Moving force> Max. force at the positioning operation.
The force is automatically adjusted corresponding to the load.
Note) Set it at 150 % when detaching the workpiece. /See 8.3⚠Caution (7) on p. 52

j <○ Area1, Area2> This is the condition that turns on the AREA output signal.
The setting condition should be
It is possible to set at Relative operation too.
The position will be Absolute (position from the origin).

Example) In case of Step no.0

【AREA】 output signal is outputted between Area 1:20 and Area 2:22.

k <○ In position> This is the condition that turns on the INP (in position) output signal.
⇒ When the electric gripper reaches the range of the target position, the INP output signal is output.
When the electric actuator enters the range of [in position], the INP output signal turns on.
When it is necessary to output the target position reaching signal earlier, make the value larger.

Note) Default: Set the value more than 【0.50】.

Example) In case of Step no.0

Position: 22 – In position: 10 = 【INP】 is outputted from the value of 12.

Pushing operation (Gripping operation)

The fingers move to the target position and hold a work piece with the set pushing force. The figure shows setting items and operation. The setting items and values are described below.

< Confirmation of reaching the target value during the pushing operation >

The "target position reaching signal" INP (in position) is generated when the target pushing force (Trigger LV) is achieved.

Also, if the actual pushing force exceeds the Trigger LV, the INP signal is turned on.

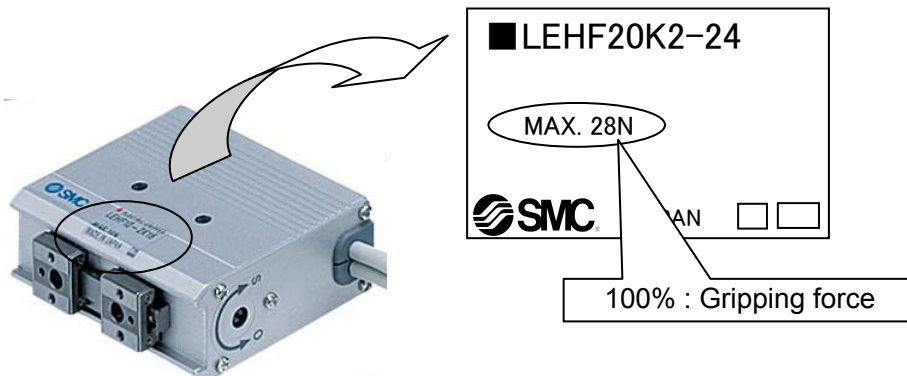
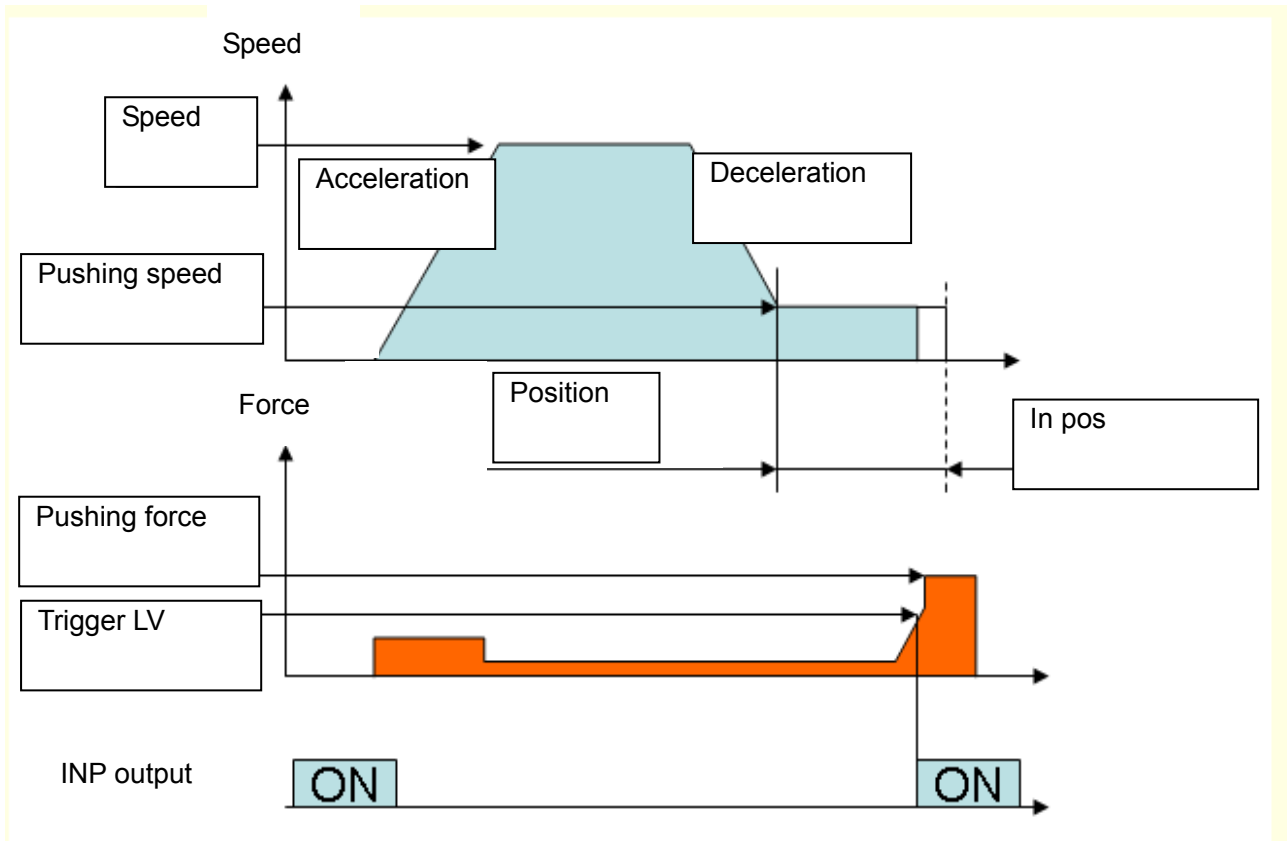

Caution

When the gripper is required to grip a work piece, use it in "pushing operation".

If it is used as "positioning operation", it can cause an error such as galling whilst it is gripping a workpiece.

Note) Use the manual override to open and close the fingers when the fingers have been galling.

/ See 8.3 Caution (2) on p. 50 and Caution (8) on p. 52

<Items and setting values of pushing operation>

Step no. 1: Pushing operation

No.	Move M	Speed mm/s	Position mm	Accel mm/s ²	Decel mm/s ²	PushingF %	TriggerLV %	PushingSp mm/s	MovingF %	Area1 mm	Area2 mm	In pos mm
0	Absolute	120	22.00	2000	2000	0	0	5	150	20.00	22.00	10.00
1	Absolute	80	5.00	2000	2000	100	100	5	150	4.00	5.00	4.00

【◎】 Need to be set · 【○】 Need to be adjusted as required

a <◎ Movement MOD> When the absolute position is required, set Absolute
When the relative position is required, set Relative

⇒ Absolute : Distance from the origin position.

Relative : Feed from the current position

b <◎ Speed> Transferring speed to the target position. ⇒ It is the speed between both fingers.

c <◎ Position> Target position. ⇒ It is the width between both fingers.

Note) Set the target position at the distance of the workpiece width +0.5 mm or more in front (the target position where pushing starts).

/ See 8.3 ⚠ Caution (11) on p. 53

d <○ Acceleration> The parameter which defines how rapidly the actuator reaches the speed set in **b**
The higher the set value, the faster it reaches the speed set in **b**.

e <○ Deceleration> The parameter which defines how rapidly the actuator comes to stop.
The higher the set value, the quicker it stops.

f <◎ Pushing force> Gripping force ratio is defined.

Note) LEHZ(J) , LEHF , LEHS series : 40% to 100%

LEHZJ10L , LEHZJ16L only : 50% to 100%

g <◎ Trigger LV> The condition at which INP output signal is turned on.
Set it at the value equivalent to

/ See 8.3 ⚠ Caution (6) on p. 51

⇒ The INP output signal is given when the target force (Trigger LV) is achieved.

The INP output signal is turned on when the generated force exceeds the value.

h <◎ Pushing speed> The gripping speed

⇒ Set the speed in the following range. If the speed is too high, the actuator or workpiece can be damaged by the impact.

Note) LEHZ(J) series: 5 to 50 mm/sec , LEHF10 series: 5 to 20 mm/sec

LEHF20,32,40 series: 5 to 30 mm/sec , LEHS series: 5 to 50 mm/sec

/ See 8.3 ⚠ Caution (3) on p. 50 and Caution (6) on p. 51

i <○ Moving force> The upper force limit for the pushing operation starting position.

The force is automatically adjusted corresponding to the load.

Note) Set it at 150 % when the work piece is removed. / See 8.3 ⚠ Caution (7) on p. 52

j <○ Area1, Area2> This is the condition that turns on the AREA output signal.

The setting condition should be

It is possible to set at Relative operation.

The position will be Absolute (position from the origin).

k <◎ In position> The transfer distance (relative value) when pushing

If the transferred distance exceeds the setting, it stops even if it is not pushing.

If the transfer distance is exceeded, the INP output signal will not be turned on. (incomplete gripping)

Example) In case of Step no.1

Position: 5 – positioning width: 4 = 1 (The position where the incomplete pushing is detected.)

Example of step data entry (1)

	a	b	c	d	e	f	g	h	i	j	k	
No.	Move M	Speed mm/s	Position mm	Accel mm/s ²	Decel mm/s ²	PushingF %	TriggerLV %	PushingSp mm/s	MovingF %	Area1 mm	Area2 mm	In pos mm
0	Absolute	120	22.00	2000	2000	0	0	5	150	20.00	22.00	10.00
1	Absolute	80	5.00	2000	2000	100	100	5	150	4.00	5.00	4.00

Step data
No. 0

Positioning
operation

- f Set [0]
- g No need to enter
- h No need to enter
- j Area1 < Area2

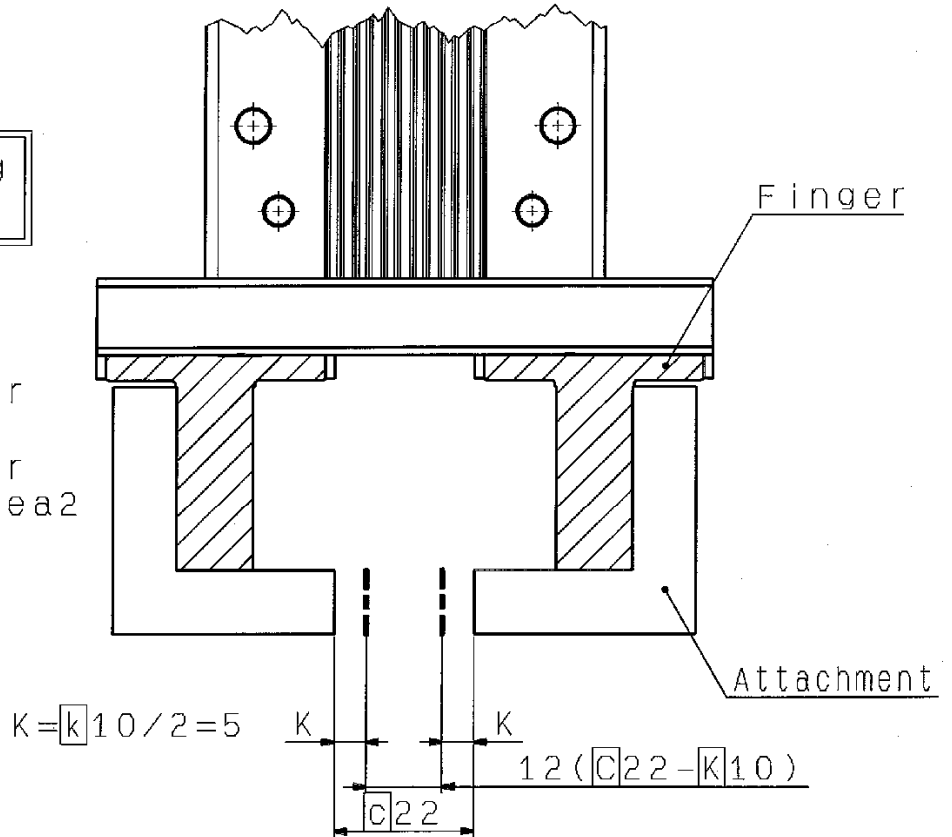

[INP]: Output condition
Reaching to the positioning width k within the specified time
... The [INP] output signal is turned on.

Step data
No. 1

Gripping
operation

$h \cdot 5 / 2 = 2.5 \text{ mm/sec}$

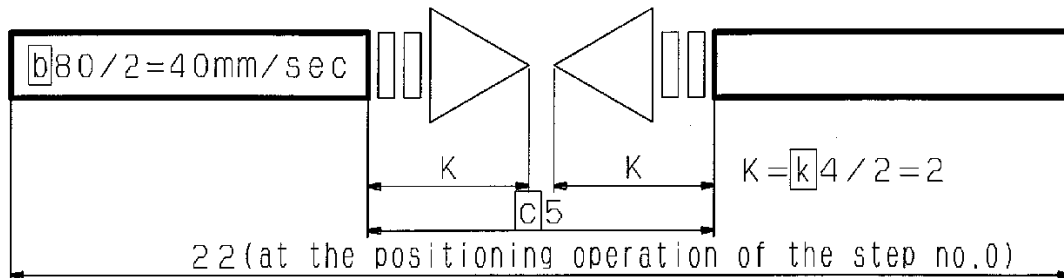

Example of step data entry (2)

	a	b	c	d	e	f	g	h	i	j	k	
No.	Move M	Speed mm/s	Position mm	Accel mm/s ²	Decel mm/s ²	PushingF %	TriggerLV %	PushingSp mm/s	MovingF %	Area1 mm	Area2 mm	In pos mm
0	Absolute	120	22.00	2000	2000	0	0	5	150	20.00	22.00	10.00
1	Absolute	80	5.00	2000	2000	100	100	5	150	4.00	5.00	4.00

Step data
No.1

Gripping
operation

Operation up to
the target Pushing
starting position

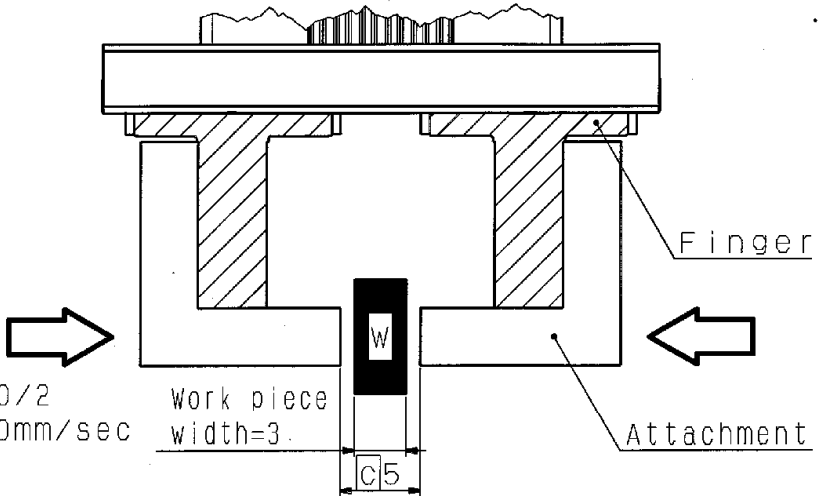

Gripping completed
(work piece exists)

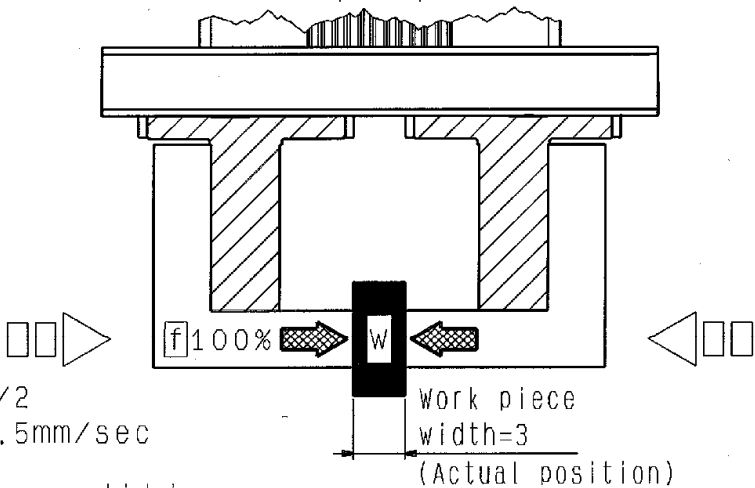

【INP】:Output condition
Actual force :100% ≥ [g]100% The 【INP】 output
[c]5 ≥ Actual position:3 ≥ 1([c]5-[k]4) ... signal is turned on.

/See 8.3 ⚠ Caution (11) on p. 53

Gripping: Not completed
(No work piece)

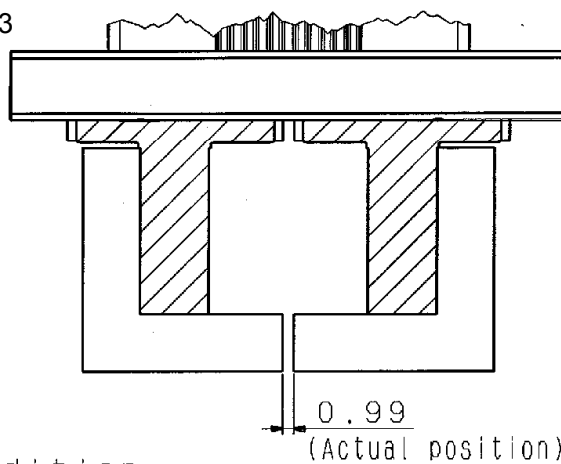

【INP】:Output condition
Actual position:0.99 < 1([c]5-[k]4) ... The 【INP】 output signal
is not turned on.

Example of step data entry (3)

< Pushing operation explained >

The gripping action is different and dependent upon the starting position and direction.
Confirm the position where the pushing operation starts.

Example)

No.	Speed mm/s	Position mm	Pushing F %	PushingSp mm/s	In pos mm
0	120	22.00	0	5	0.50
1	120	8.00	0	5	0.50
2	120	10.00	100	5	9.00

Condition 1) In case the pushing operation is to Step no. 2

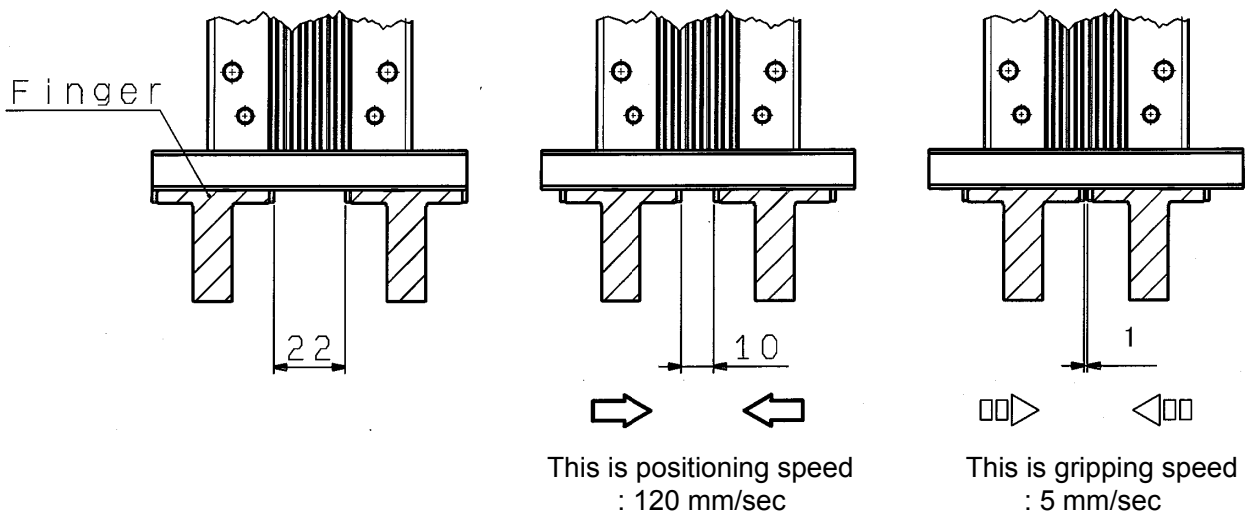

Condition 2) In case the pushing operation is to Step no. 2

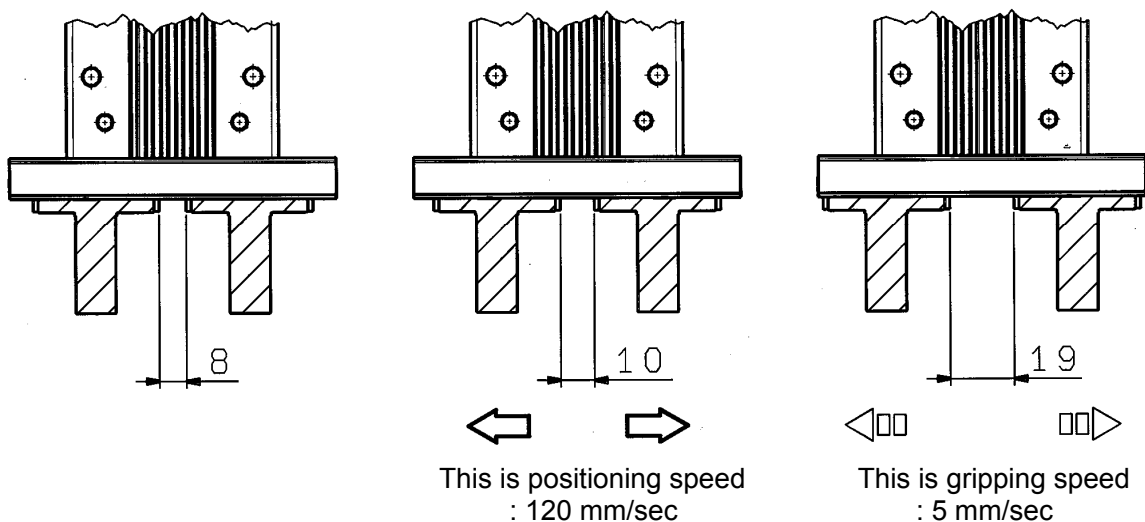

⚠ Caution

When the operation is discontinued by EMG-Stop or drive-stop

Drive-stop and the pushing operation is commanded just after restart, the moving direction depends on the operation-starting position. / See 8.3 ⚠ Caution (2) on p. 49

Operating procedure and input / output signals for each operation.

The input / output signal and the operation description for operating this electric actuator are as follows.

1) Signals along with the operation procedures

In case the operation order is

1. Supply power to the motor → 2. Return to origin → 3. Step no. 1 → 4. Step no. 2 → 5. Cut power to the motor

Procedure	Input signal	Output signal to the input signal	Operation description
1	SVON (Servo on) [●]	SVRE (Servo ready) [●]	Power is supplied to the motor, and detection of the magnetic pole position starts. => Completion.
2	SETUP [●]	SETON [●] INP (IN position) [●]	Returning to the origin starts. =>Completion.
3	IN0 [●] IN1 [] IN2 [] IN3 [] IN4 [] IN5 [] ↓ DRIVE [●]⇒[](Note 3) 5)	OUT0 [●] OUT1 [] OUT2 [] OUT3 [] OUT4 [] OUT5 [] } Note 3)4) ↓ After reaching of target position, INP [●] After stopping motion, BUSY []	Step no. 1 is selected, and the operation starts. ⇒ Complete.
4	IN0 [] IN1 [●] IN2 [] IN3 [] IN4 [] IN5 [] ↓ DRIVE [●]⇒[](Note 3) 5)	OUT0 [] OUT1 [●] OUT2 [] OUT3 [] OUT4 [] OUT5 [] } Note 3)4) ↓ After reaching of target position, INP [●] After stopping motion, BUSY []	Select the step no. 2, and the operation starts. ⇒ Complete.
5	SVON []	SVRE [] SETON [●] Note 2) INP [●]	Power to the motor is cut.

Note 1) [●] means ON, [] means OFF.

Note 2) The origin has been recognized when the operation is repeated, so it can operate without the procedure item 2.

Note 3) The "OUT*" signals are reset during the rising edge of the Drive signal. The "OUT*" signal which follows the "IN*" signal are outputted at the falling edge of the "drive" signal.

Note 4) When the alarm is generated, the alarm group is displayed.
Please confirm the controller (LEC series) manual for a detailed content of the alarm.

Note 5) Leave an interval of 15ms (the recommendation is 30ms) or more between input signals and maintain the state of the signal for 15ms (the recommendation is 30ms) or more, because PLC processing delays and controller scanning delays can occur.

2) Signals when stopped: In the event when “EMG” is used

/ See 8.3▲ Caution (9) on p. 52

The operating sequence is 1. “Stop” → 2. Release the “Stop”

Procedure	Input signal	Output signal for the input signal	Operation description
1	EMG: Not energizing (TB / Stop switch: Locking)	* ESTOP[] SVRE [] SETON [●]	Power to the motor is cut by the “Stop” command regardless of whether it is operating or stopping.
2	EMG: Energizing (TB / Stop switch: Releasing)	* ESTOP[●] SVRE [●] SETON [●] Note 2)	The stop is released.

Note 1) [●] means ON, [] means OFF. * means negative logic

Note 2) SETON signal does not change after releasing the “STOP”.

Note 3) If the stop is input from the EMG or RESET terminal or the stop-switch on the connected Teaching Box during pushing operation, the actuator stop. (“Busy” signal turns OFF) And if the actuator stop within the range of “Position”± “In pos” defined in step data, output signal “INP” turns ON.

3) Signal to identify the width of a work piece

The output signal step data as shown below is for when two different widths of work piece (8 mm and 3 mm) are held by the grippers.

No.	Position	Pushing F	TriggLV	Area1	Area2	In pos
	mm	%	%	mm	mm	mm
0	10.00	100	100	5.00	10.00	9.00

Condition	Output signal	Condition with which the output signal is given
In the case where the work piece with width of 8 mm is held	AREA [●]	Area 1 ≤ ≤ Area 2
	INP [●]	Actual force: 100 ≥ Trigger LV Position ≥ ≥ 1 (position – positioning width)
In the case where the work piece with width of 3 mm is held	AREA []	≤ Area 1 ≤ Area 2
	INP [●]	Actual force: 100 ≥ Trigger LV Position ≥ ≥ 1 (position – positioning width)
In the case any work piece is not held	AREA []	≤ Area 1 ≤ Area 2
	INP []	Actual force: 0 < Trigger LV Position ≥ 1 ≥ (position – positioning width)
	OUT* [●]⇒[] Note 2)	Gripping: not completed

Note 1) [●] means ON, [] means OFF.

Note 2) The “OUT*” signals are reset during the rising edge of the Drive signal. The “OUT*” signal which follows the “IN*” signal is outputted at the falling edge of the “drive” signal and the “OUT*” signal turns OFF when the gripping is not completed. See the controller operation manual for the detail of “OUT*” signal.

5.4 Parameter setting method

Initial setting for the basic parameters

Refer to the controller's (LEC series) operation manual for detail.

As the "basic parameter" is unique data of each actuator, if an actuator other than the electric gripper is used, refer to the operation manual of each actuator and the controller's (LEC series) operation manual for the basic parameter.

Description (Extract)	Initial input value	Input range
Controller ID	1	1 to 64 Note 1)
IO pattern	1: 64	-
Acceleration/ deceleration pattern	1:Trapezoid - motion	-
S-motion ratio	0	-
Stroke (+)	1000.00	-
Stroke (-)	-1000.00	-
Maximum speed	Max. speed of each product	Step data input limit: Max. speed of each product
Maximum acceleration / deceleration	2,000	Step data input limit: 2000 at the maximum
Default In positioning	0.50	-
Origin offset	1.00 / LEHZ,LEHF 0.00/ LEHS	Note 2)
Maximum pushing force	100	Step data input limit: Maximum 100
Parameter protect	1:Common+StepDate	Changeable parameter 1: Common + StepData, 2: Common
Enable switch	2: Disable	Select 1:Enable or 2:Disable when using a teaching box
Model name	Part no. of each product	Only the English characters and numbers are changeable.
W-area output end 1	0.00	-
W-area output end 2	0.00	-
Origin correction data	0.00	-

Note1) Become effective after restarting the controller.

Note2) The origin offset is used for the "return to origin". See the following.

<Return to origin>

Before the positioning and pushing operation, "return to origin" is necessary to establish the origin. The current position value of the electric gripper increases if the closed fingers open (move in the CW direction). (The finger moving direction to be increased cannot be changed.)

1) Flow of return to origin

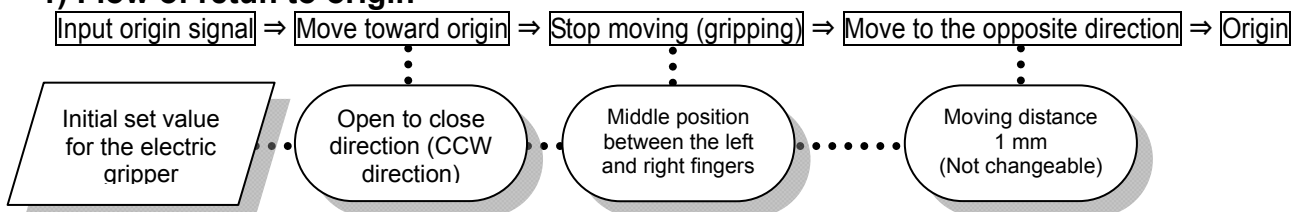

2) Origin offset

The origin offset means the value of the origin. (Origin offset = origin)

The moving amount in the opposite direction is set at 1 mm (not changeable), so add/ subtract 1 mm when the origin offset parameter is changed.

When the parameter is changed, the current position is changed. The step data should be checked again.

- a) In case the work piece width is to be set to "0". Origin offset: 1 (LEHZ(J),LEHF initial set value)
(LEHS initial set value "0")

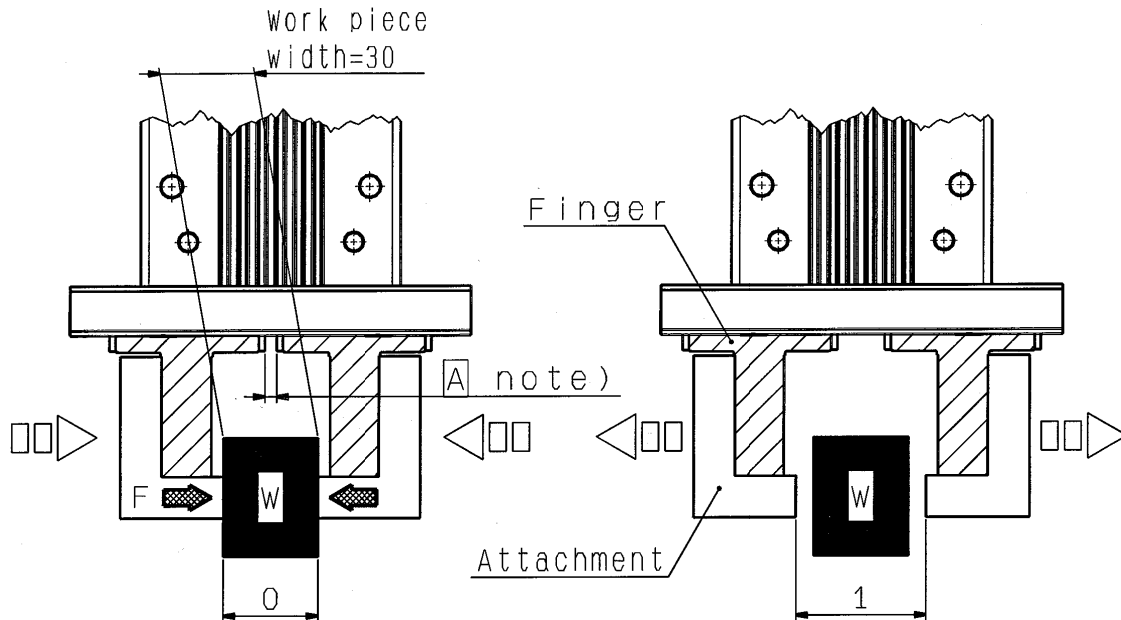

Note) When the work piece is used to define the origin, the stroke (moving distance) will be shortened by A mm, so check the step data again.

- b) In case the work piece width is to be set to "30". Origin offset: 31

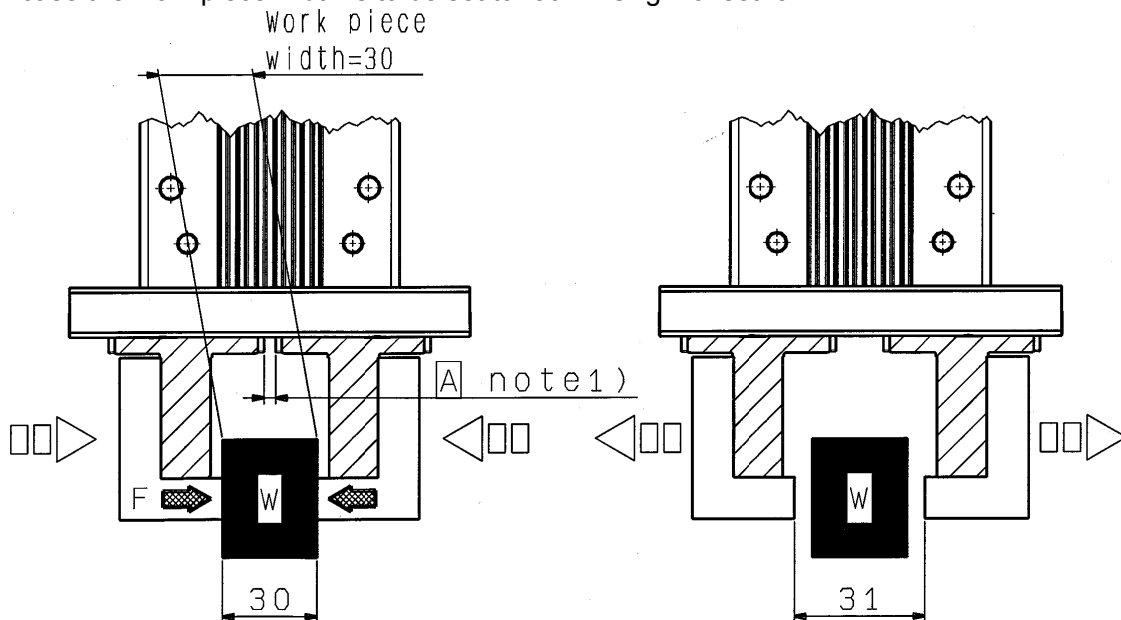

Note 1) If the work piece is used to define the origin, the stroke (moving distance) will be shortened by A mm, so check the step data again.

Note 2) In case the return direction is CW (inward gripping)

When the fingers are moved in the close-to-open direction (CW direction), the position value is increased. Therefore, if the work width of 30 is to be set, enter 29 to the origin offset.

Work piece length: 30 – moving amount: 1= origin offset: 29

Initial setting for the ORIG parameters

Refer to the controller's (LEC series) operation manual for detail.

As the "ORIG parameter" is unique data of each actuator, if an actuator other than the electric gripper is used, refer to the operation manual of each actuator and the controller's (LEC series) operation manual for the "ORIG parameters".

Description (Extract)	Initial input value	Input range
ORIG direction	2:CCW	1: CW (Internal grip direction : Both ends) 2: CCW (External grip direction : Center) Note 1)
ORIG mode	1: Stop	-
ORIG limit	100	40 to 100 / LEHZ(J), LEHF, LEHS 50 to 100 / LEHZJ10L, LEHZJ16L only Note 2)
ORIG time	100	-
ORIG speed	10	5 to 50 / LEHZ(J) , LEHS 5 to 20 / LEHF10 5 to 30 / LEHF20/32/40 Note 3)
ORIG ACC/DEC	2,000	-
Creep speed	10	-
ORIG sensor	0: Disable	-

Note1) Note1) Become effective after restarting the controller.

It is recommended to set the directions of return to origin and work piece gripping to the same direction. / See 8.3 ⚠ Caution (10) on p. 53

Note2) It is recommended to set ORIG limit and gripping force to the same value.

Note3) It is recommended to set ORIG speed and gripping speed to the same value.

Note4) Return to origin cannot return while operating. / See 7.1 ⚠ Caution (4) on p. 41

6. Wiring of cables / Common precautions

Warning

1. **Adjusting, mounting or wiring change should never be done before disconnecting the power supply to the product.**

Electrical shock, malfunction and damage can result.

2. **Do not disassemble the cables.**

Use only specified cables.

3. **Do not connect or disconnect the wires, cables and connectors when the power is turned on.**

Caution

1. **Wiring securely. Do not apply any voltage to the terminals other than those specified in the Operation Manual.**

2. **Wire the connector securely.**

3. **Take appropriate measures against noise.**

Noise in a signal line may cause malfunction. As a countermeasure separate the high voltage and low voltage cables, and shorten the wiring lengths, etc.

4. **Do not route input/output wires and cables together with power or high voltage cables.**

The product can malfunction due to interference of noise and surge voltage from power and high voltage cables to the signal line. Route the wires of the product separately from power or high voltage cables.

5. **Take care that actuator movement does not catch cables.**

6. **Operate with all wires and cables secured. Avoid bending cables at sharp angles where they enter the product.**

7. **Avoid twisting, folding, rotating or applying an external force to the cable.**

Risk of electric shock, wire breakage, contact failure and loss of control of the product can happen.

8. **Fix the cable protruding from the product in place before using.**

The motor and lock cables are not robotic type cables and can be damaged when moved. Therefore fix the cables and the connectors (part "A" in figure below) when set up.

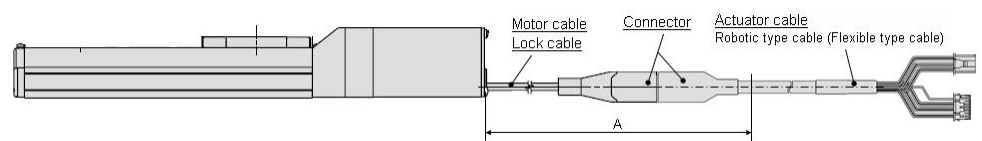

9. **Select "Robotic type cables" in case of inflecting actuator-cable repeatedly. And do not put cables into a flexible moving tube with a radius smaller than the specified value. (Min. 50mm).**

Risk of electric shock, wire break, contact failure and loss of control for the product can happen if "Standard cables" are used in case of inflecting the cables repeatedly.

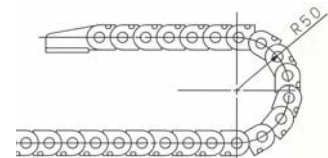

10. **Confirm correct insulation of the product.**

Poor insulation of wires, cables, connectors, terminals etc. can cause interference with other circuits. Also there is the possibility that excessive voltage or current may be applied to the product causing damage.

11. The speed / pushing force may vary, depending on the cable length, load and mounting conditions etc.

If the cable length exceeds 5m, the speed/pushing force will be reduced 10% per 5m as the maximum. (if cable length is 15m: 20% reduction as the maximum.)

[Transportation]

Caution

1. Do not carry or swing the product by the cables.

7. Electric actuators / Common precautions

7.1 Design and selection

Warning

1. **Be sure to read the operation manual (this manual and the one for the controller: LEC series).**

Handling or usage/operation other than that specified in the Operation Manual may lead to breakage and operation failure of the product.

Any damage attributed to the use beyond the specifications is not guaranteed.

2. **There is a possibility of dangerous sudden action by the product if sliding parts of machinery are twisted due to external forces etc.**

In such cases, human injury may occur, such as by catching hands or feet in the machinery, or damage to the machinery itself may occur. Design the machinery should be designed to avoid such dangers.

3. **A protective cover is recommended to minimize the risk of personal injury.**

If a driven object and moving parts of the product are in close proximity, personal injury may occur. Design the system to avoid contact with the human body.

4. **Securely tighten all stationary parts and connected parts so that they will not become loose.**

When the product operates with high frequency or is installed where there is a lot of vibration, ensure that all parts remain secure.

5. **Consider a possible loss of power source.**

Take measures to prevent injury and equipment damage even in the case of a power source failure.

6. **Consider behavior of emergency stop of whole system.**

Design the system so that human injury and/or damage to machinery and equipment will not be caused, when it is stopped by a safety device for abnormal conditions such as a power outage or a manual emergency stop of whole system.

7. **Consider the action when operation is restarted after an emergency stop or abnormal stop of whole system.**

Design the system so that human injury or equipment damage will not occur upon restart of operation of whole system.

8. **Disassembly and modification is prohibited**

Do not modify or reconstruct (including additional machining) the product. An injury or failure can result.

9. **Do not use the stop signal, "EMG" of the controller and stop switch on the teaching box as the emergency stop of system.**

The stop signal, "EMG" of controller and the stop switch on the teaching box are for decelerating and stopping the actuator.

Design the system with an emergency stop circuit which is applied relevant safety standard separately.

Caution

1. **Operate within the limits of the maximum usable stroke.**

The product will be damaged if it is used with the stroke which is over the maximum stroke. Refer to the specifications of the product.

- 2. When the product repeatedly cycles with partial strokes, operate it at a full stroke at least once every 10 strokes.**
Otherwise, lubrication can run out.
- 3. Do not use the product in applications where excessive external force or impact force is applied to it.**
The product can be damaged.
- 4. Returning to origin cannot be done during the operation.**
It cannot be done during positioning operation, pushing operation and pushing.

7.2 Mounting

Warning

- 1. Install and operate the product only after reading the Operation Manual carefully and understanding its contents. Keep the manual in a safe place future reference.**
- 2. Observe the tightening torque for screws.**
Unless stated otherwise, tighten the screws to the recommended torque for mounting the product.
- 3. Do not make any alterations to this product.**
Alterations made to this product may lead to a loss of durability and damage to the product, which can lead to human injury and damage to other equipment and machinery.
- 4. When an external guide is used, connect the moving parts of the product and the load in such a way that there is no interference at any point within the stroke.**
Do not scratch or dent the sliding parts of the table or mounting face etc., by striking or holding them with other objects. The components are manufactured to precise tolerances, so that even a slight deformation may cause faulty operation or seizure.
- 5. Do not use the product until you verify that the equipment can be operated correctly.**
After mounting or repair, connect the power supply to the product and perform appropriate functional inspections to check it is mounted correctly.
- 6. When attaching to the work piece, do not apply strong impact or large moment.**
If an external force over the allowable moment is applied, it may cause looseness in the guide unit, an increase in sliding resistance or other problems.
- 7. Maintenance space**
Allow sufficient space for maintenance and inspection.

7.3 Handling

Warning

- 1. Do not touch the motor while in operation.**
The surface temperature of the motor can increase to approx. 90°C to 100°C due to operating conditions. Energizing alone may also cause this temperature increase. As it may cause burns, do not touch the motor when in operation.
- 2. If abnormal heating, smoking or fire, etc. occurs in the product, immediately turn off the power supply.**

3. Immediately stop operation if abnormal operation noise or vibration occurs.

If abnormal operation noise or vibration occurs, the product may have been mounted incorrectly. Unless operation of the product is stopped for inspection, the product can be seriously damaged.

4. Never touch the rotating part of the motor or the moving part of the actuator while in operation.

5. When installing, adjusting, inspecting or performing maintenance on the product, controller and related equipment, be sure to turn off the power supply to each of them. Then, lock it so that no one other than the person working can turn the power on, or implement measures such as a safety plug.

⚠ Caution

1. Keep the controller and product combined as delivered for use.

The product is set in parameters for shipment. If it is combined with a different product parameter, failure can result.

2. Check the product for the following points before operation.

- a) Damage to power supply line and signal line.
- b) Looseness of the connector to each power line and signal line.
- c) Looseness of the actuator /cylinder and controller /driver mounting
- d) Abnormal operation
- e) Emergency stop of the total system

3. When more than one person is performing work, decide on the procedures, signals, measures and resolution for abnormal conditions before beginning the work. Also, designate a person to supervise work other than those performing work.

4. Actual speed of the product will be changed by the workload.

Before selecting a product, check the catalog for the instructions regarding selection and specifications.

5. Do not apply a load, impact or resistance in addition to a transferred load during return to origin.

In the case of the return to origin by pushing force, additional force will cause displacement of the origin position since it is based on detected motor torque.

6. Do not remove the nameplate.

7. Operation test should be performed by low speed. Start operation by predefined speed after confirming there are no problems.

[Ground]

⚠ Warning

- 1. Please give the ground to the actuator.**
- 2. The ground should be exclusive use. (Less than 100Ω)**
- 3. The ground cable length should be as short as possible.**

[Unpackaging]

⚠ Caution

1. Check the received product is as ordered.

If the different product is installed from the one ordered, injury or damage could result.

7.4 Operating environment

Warning

1. Avoid use in the following environments.

- Locations where a large amount of dusts and cutting chips are airborne.
- Locations where the ambient temperature is outside the range (refer to specifications).
- Locations where the ambient humidity is outside the range (refer to specifications).
- Locations where corrosive gas, flammable gas, sea water, water and steam are present.
- Locations where strong magnetic or electric fields are generated.
- Locations where direct vibration or impact is applied to the product.
- Areas that are dusty, or are exposed to splashes of water and oil drops.
- Areas exposed to direct sunlight (ultraviolet ray).

2. Do not use in an environment where the product is directly exposed to liquid, such as cutting oils.

If cutting oils, coolant or oil mist contaminates the product, failure or increased sliding resistance can result.

3. Install a protective cover when the product is used in an environment directly exposed to foreign matters such as dust, cutting chips and spatter.

Play or increased sliding resistance can result.

4. Shade the sunlight in the place where the product is applied with direct sunshine.

5. Shield the product if there is a heat source nearby.

When there is a heat source surrounding the product, the radiated heat from the heat source can increase the temperature of the product beyond the operating temperature range. Protect it with a cover, etc.

6. Grease oil can be decreased due to external environment and operating conditions and it deteriorates lubrication performance to shorten the life of the product.

[Storage]

Warning

1. Do not store the product in a place in direct contact with rain or water drops or is exposed to harmful gas or liquid.

2. Store in an area that is shaded from direct sunlight and has a temperature and humidity within the specified range (-10°C to 60°C and 90%RH or less No condensation or freezing).

3. Do not apply vibration and impact to the product during storage.

7.5 Maintenance

Warning

1. Do not disassemble or repair the product.

Fire or electric shock can result.

2. Before modifying or checking the wiring, the voltage should be checked with a tester 5 minutes after the power supply is turned off.

Electrical shock can result.

Caution

1. Maintenance should be performed according to the procedure indicated in the Operating Manual.

Incorrect handling can cause an injury, damage or malfunction of equipment and machinery.

2. Removal of product

When equipment is serviced, first confirm that measures are in place to prevent dropping of work pieces and run-away of equipment, etc, and then cut the power supply to the system. When machinery is restarted, check that operation is normal with actuators in the proper positions.

[Lubrication]

⚠ Caution

1. The product has been lubricated for life at manufacturer, and does not require lubrication in service.

Contact SMC if lubrication will be applied

8. Electric Gripper/Specific Product Precautions

8.1 Design and selection

⚠ Warning

1. Keep the specified gripping point.

If the specified gripping range is exceeded, excessive moment is applied to the sliding part of the finger, which may have an adverse affect on the life of the product.

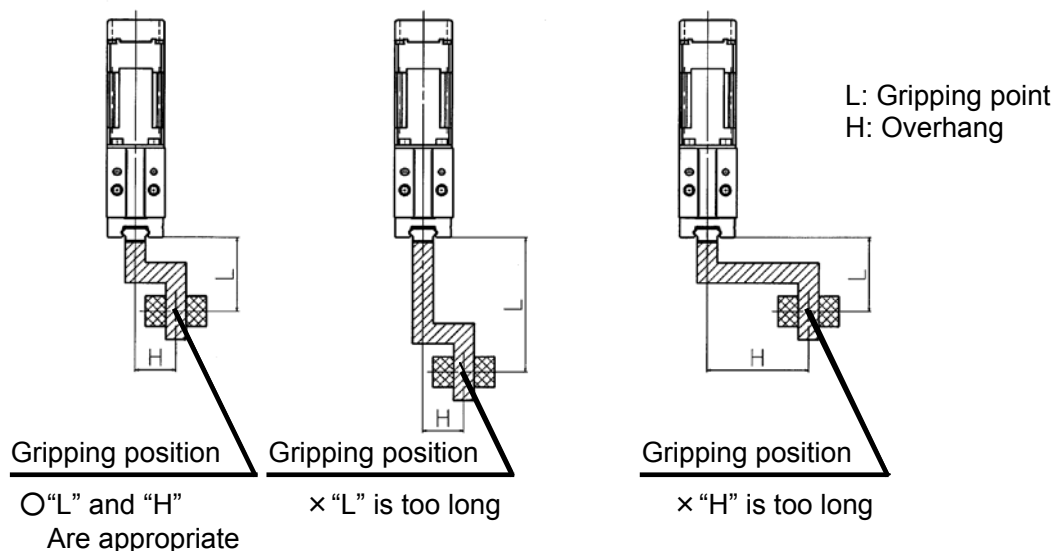

2. Design the attachment to be lightweight and of minimum length.

A long and heavy attachment will increase inertia force when the product is opened or closed, which causes play at the finger. Even if the gripping point of the attachment is within a specified range, design it to be short and lightweight as possible.

For a long or large work piece, select a model of a larger size or use two or more grippers together.

3. Reserve a gripping space for attachment when a work piece is extremely thin.

Without a gripping space, the product cannot perform stable gripping, and the displacement of a work piece or gripping failure can result.

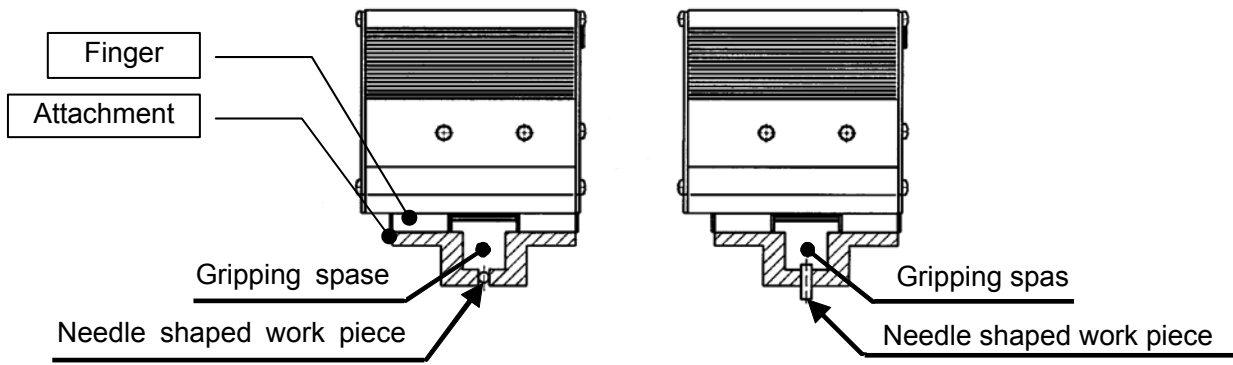

4. Select the model that allows for gripping force in relation to the weight of a work piece, as appropriate.

The selection of inappropriate model can cause dropping of a work piece. Gripping force should be from 10 to 20 times (LEHZ(J),LEHF) or 7 to 13 times (LEHS) of the weight of the object to be conveyed.

<The accuracy of the specified gripping force>

Part no.	The accuracy of the specified gripping force		
	+/-30%F.S.	+/-25%F.S.	+/-20%F.S.
LEHZ(J)	10,16	20,25	32,40
LEHF	10	20	32,40
LEHS	10	20	32,40

5. Do not use the product in such a way that excessive external force (including vibration) or impact force will be applied.

It may lead to breakage or galling, which causes operation failure. Do not apply impact and vibration outside of the specifications.

6. Select the model that allows for penning and closing width relative to a work piece.

The selection of an inappropriate model will cause gripping at unexpected positions due to variable opening and closing width of the product and the diameter of a work piece the product can handle. It is also necessary to make a larger stroke to overcome backlash created when the product will open after gripping.

8.2 Mounting



Warning

1. Do not drop or hit the gripper when mounting to avoid scratches and dents.

Even slight deformation can cause the deterioration of accuracy and operation failure.

2. Tighten the attachment mounting screws to the specified torque.

Tightening to a torque over the specified range can cause operation failure, and insufficient torque can cause displacing or dropping of the attachment.

Mounting of attachment to finger

The attachment should be mounted at the torque specified in the following table by screwing the bolt into the finger mounting female thread and hole.

<LEHZ series>

Part no.	Bolt	Max. tightening torque [Nm]
LEHZ(J)10(L)K2-4	M2.5×0.45	0.3
LEHZ(J)16(L)K2-6	M3×0.5	0.9
LEHZ(J)20(L)K2-10	M4×0.7	1.4
LEHZ(J)25(L)K2-14	M5×0.8	3.0
LEHZ32K2-22	M6×1	5.0
LEHZ40K2-30	M8×1.25	12.0

<LEHF series>

Part no.	Bolt	Max. tightening torque [Nm]
LEHF10K2-*	M2.5×0.45	0.3
LEHF20K2-*	M3×0.5	0.9
LEHF32K2-*	M4×0.7	1.4
LEHF40K2-*	M4×0.7	1.4

<LEHS series>

Part no.	Bolt	Max. tightening torque [Nm]
LEHS10(L)K3-4	M3×0.5	0.9
LEHS20(L)K3-6	M3×0.5	0.9
LEHS32K3-8	M4×0.7	1.4
LEHS40K3-12	M5×0.8	3.0

< LEHZ Mounting >

Mounting by screws to the side of the body

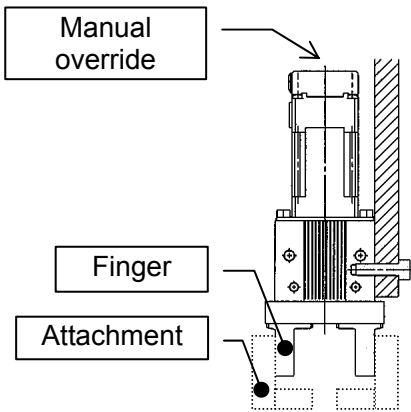

Part no.	Bolt	Max. tightening torque [Nm]	Max. thread depth L[mm]
LEHZ(J)10(L)K2-4	M3×0.5	0.9	6
LEHZ(J)16(L)K2-6	M4×0.7	1.4	6
LEHZ(J)20(L)K2-10	M5×0.8	3.0	8
LEHZ(J)25(L)K2-14	M6×1	5.0	10
LEHZ32K2-22	M6×1	5.0	10
LEHZ40K2-30	M8×1.25	12.0	14

Mounting by screws to the mounting plate

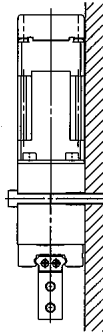

Part no.	Bolt	Max. tightening torque [Nm]
LEHZ(J)10(L)K2-4	M3×0.5	0.9
LEHZ(J)16(L)K2-6	M3×0.5	0.9
LEHZ(J)20(L)K2-10	M4×0.7	1.4
LEHZ(J)25(L)K2-14	M5×0.8	3.0
LEHZ32K2-22	M5×0.8	3.0
LEHZ40K2-30	M6×1	5.0

Mounting by screws to the back of the body

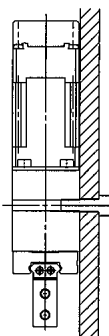

Part no.	Bolt	Max. tightening torque [Nm]	Max. thread depth L[mm]
LEHZ(J)10(L)K2-4	M4×0.7	1.4	6
LEHZ(J)16(L)K2-6	M4×0.7	1.4	6
LEHZ(J)20(L)K2-10	M5×0.8	3.0	8
LEHZ(J)25(L)K2-14	M6×1	5.0	10
LEHZ32K2-22	M6×1	5.0	10
LEHZ40K2-30	M8×1.25	12.0	14

< LEHF Mounting >

Mounting by screws to the side of the body

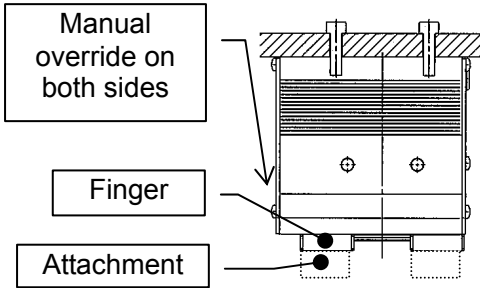

Part no.	Bolt	Max. tightening torque [Nm]	Max. thread depth L [mm]
LEHF10K2-*	M4×0.7	1.4	7
LEHF20K2-*	M5×0.8	3.0	8
LEHF32K2-*	M6×1	5.0	10
LEHF40K2-*	M6×1	5.0	10

Mounting by screws to the mounting plate

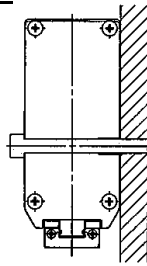

Part no.	Bolt	Max. tightening torque [Nm]
LEHF10K2-*	M4×0.7	1.4
LEHF20K2-*	M5×0.8	3.0
LEHF32K2-*	M6×1	5.0
LEHF40K2-*	M6×1	5.0

Mounting by screws to the back of the body

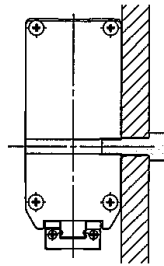

Part no.	Bolt	Max. tightening torque [Nm]	Max. thread depth L [mm]
LEHF10K2-*	M5×0.8	3.0	10
LEHF20K2-*	M6×1	5.0	12
LEHF32K2-*	M8×1.25	12.0	16
LEHF40K2-*	M8×1.25	12.0	16

< LEHS Mounting >

Mounting by screws to the mounting plate

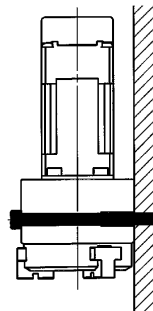

Part no.	Bolt	Max. tightening torque [Nm]
LEHS10(L)K3-4	M3×0.5	0.9
LEHS20(L)K3-6	M5×0.8	3.0
LEHS32K3-8	M6×1	5.0
LEHS40K3-12	M6×1	5.0

Mounting by screws to the back of the body

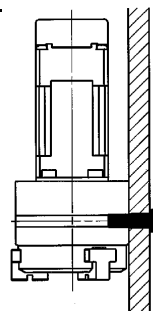

Part no.	Bolt	Max. tightening torque [Nm]	Max. thread depth L [mm]
LEHS10(L)K3-4	M4×0.7	1.4	6
LEHS20(L)K3-6	M6×1	5.0	10
LEHS32K3-8	M8×1.25	12.0	14
LEHS40K3-12	M8×1.25	12.0	14

3. Tighten the product mounting screws to the specified torque.

Tightening to a torque over the specified range can cause operation failure, and insufficient torque can cause displacing or dropping of the attachment.

4. When fixing the attachment to the finger, avoid applying excessive torque to the finger.

Play or deteriorated accuracy can result.

5. The mounting face has holes and slots for positioning. Make use of them if necessary.

6. When the work piece has to be removed after the power has been switched off, it can be removed by using the manual override or by removing the finger attachments.

If the manual override is used to remove the workpiece allow sufficient space to access the manual override screw. Do not apply excessive torque to the manual override that could lead to damage and malfunction of the product.

7. When gripping the work piece leave space in the finger movement direction to prevent the load from being concentrated on one finger and to allow for work piece mis-alignment.

For the same reason when aligning the work piece using the gripper finger movement, minimize the frictional resistance created by the movement of the workpiece.

The finger can be displaced or play or breakage can occur.

8. Perform adjustment and confirmation to ensure there is no external force applied to the finger.

If the finger is subject to repetitive lateral load or impact load, it can cause play or breakage and the lead screw can get stuck, which results in operation failure. Allow a clearance to prevent the work piece or the attachment from hitting gripper product at the end of the stroke.

1) Stroke end when fingers are open

○ With clearance

× Without clearance

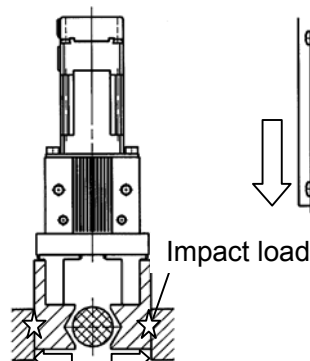
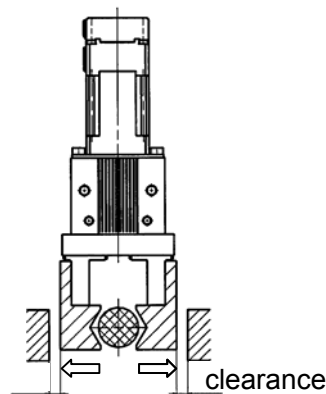

clearance

2) Stroke end when gripper is moving

○ With clearance

× Without clearance

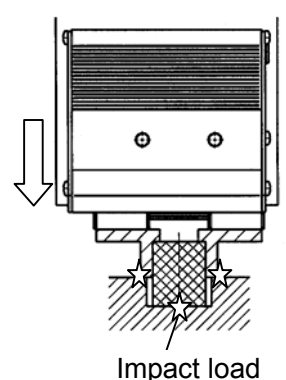
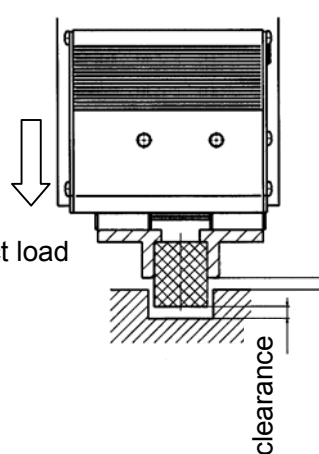

clearance

clearance

3) When turning over

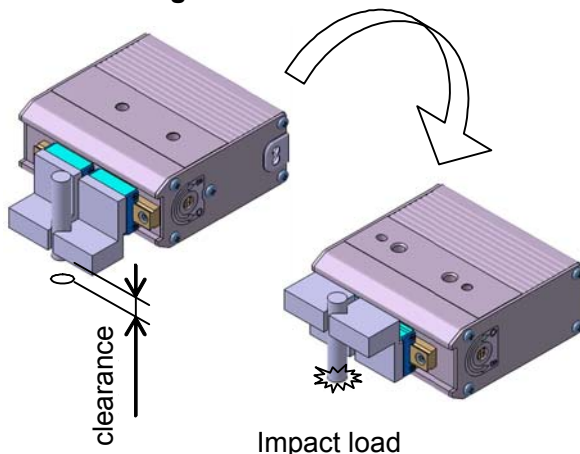

9. When mounting a work piece, align it with the product carefully to prevent excessive force to the finger.

In particular, during a trial run, operate the product manually or at a low speed and check that the safety is assured without impact.

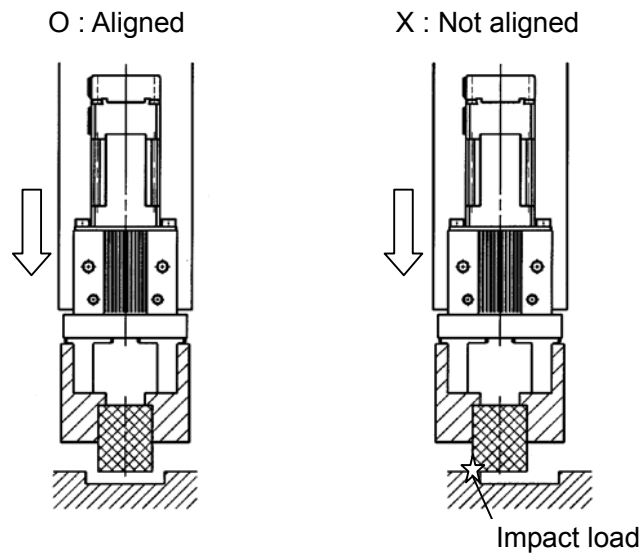

10. When using the LEHZJ series, please affix the "protection seal to prevent ingress of dust" provided.

Otherwise machining chips and fine particles may get into the product from the outside, leading to operation failure.

This is equivalent to IP50 (dust-proof). Please note that it does not provide a drip-proof function.

8.3 Handling

 **Caution**

1. The parameters of the stroke and the open and close speed are for both fingers.

The stroke and the open and close speed of one finger will be halved from a set parameter.

2. When gripping a work piece by the product, be sure to use in pushing operation.

Also, do not hit the work piece to the finger and attachment in positioning operation or in the range of positioning operation.

Otherwise, the lead screw can get caught and cause operation failure.

However, if the work piece cannot be gripped in pushing operation (such as a plastically deformed work piece, rubber component, etc.), you can grip it in positioning operation with consideration to the elastic force of the work piece. In this case, keep the driving speed for impact specified in item 3.

3. Keep the following driving speed range for pushing operation.

LEHZ(J) series: 5 to 50 mm/sec

LEHF10 series: 5 to 20 mm/sec , LEHF20/32/40 series: 5 to 30 mm/sec

LEHS series: 5 to 50 mm/sec

Operation at the speed outside of the range can get the lead screw caught and cause operation failure.

Please set the [Pushing force] and the [TriggerLV] within the limitation range. /See 8.3Caution(6)

4. There is no backlash effect in pushing operation.

The return to origin is done by pushing operation.

When the positioning operation, the gap is caused by backlash in the finger. Please set "Position" in consideration of backlash.

5. Do not change the setting of the electric power saving mode.

When pushing operation is continued, the heat generated by the motor can cause operation failure. This is due to the self-lock mechanism in the lead screw, which makes the product keep the gripping force. To save the energy in this situation where the product is to be stand-by or continue to grip for extended periods of time, the product will be controlled to reduce current consumption (to 40% automatically after it has gripped a work piece once).

If there is the reduction of gripping force seen in the product after a work piece has been gripped and deformed over certain amount of time, contact SMC.

6. INP output signal

1) Positioning operation

When the product comes within the set range by step data [In position], output signal will be turned on. Initial value: Set to [0.50] or higher.

2) Pushing operation

When the gripping force exceeds the [TriggerLV] value the INP (In position) output signal is turned on. Please set the [Pushing force] and the [TriggerLV] within the specified range.

- a. To ensure that the actuator pushes the workpiece by the inputted [pushing force], it is recommended that the [TriggerLV] is set to the same value as the [pushing force].
- b. When the [TriggerLV] and [pushing force] are set to be less than the lower limit of the specified range, there is the possibility that the INP output signal will be switched on from the pushing operation start position.

<INP output signal for each controller version>

●SV1.0 or later

The "INP output signal" remains "ON" without depending on the "TriggerLV" when the operation mode automatically switches to the electric power saving mode after the completion of the pushing operation.

●SV0.6* or before

a. "TriggerLV" of 40%. (Same value as electric power saving mode)

The "INP output signal" remains "ON" when the operation mode automatically switches to the electric power saving mode after the completion of the pushing operation.

b. "TriggerLV" of 40% or more

The "INP output signal" turns " ON " after the completion of the pushing operation. The "INP output signal" is turned "OFF" when the operation mode is switched to the electric power saving mode by the "auto motor-current down".

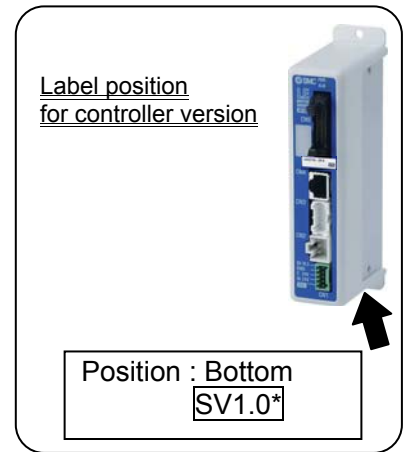

[Pushing force] and the [TriggerLV] within the limitation range

LEHZ series

Motor size	Pushing speed [mm/sec]	Pushing force
Standard	41 to 50	50% to 100%
	5 to 40	40% to 100%
Compact	31 to 50	70% to 100%
	21 to 30	50% to 100%
	5 to 20	40% to 100%

LEHZJ series

Motor size	Body size	Pushing speed [mm/sec]	Pushing force
Standard	10 , 16 20 , 25	41 to 50	50% to 100%
		5 to 40	40% to 100%
Compact	10L , 16L	21 to 50	80% to 100%
		11 to 20	60% to 100%
		5 to 10	50% to 100%
	20L , 25L	31 to 50	70% to 100%
		21 to 30	50% to 100%
		5 to 20	40% to 100%

LEHF series

Pushing speed [mm/sec]	Pushing force
21 to 30	50% to 100%
5 to 20	40% to 100%

LEHS series

Motor size	Pushing speed [mm/sec]	Pushing force
Standard	41 to 50	50% to 100%
	5 to 40	40% to 100%
Compact	31 to 50	80% to 100%
	11 to 30	60% to 100%
	5 to 10	40% to 100%

7. When releasing the work piece, set the Moving force to 150%.

If the torque is too small when a work piece is gripped during the pushing operation, the finger/workpiece can become galled and the gripper is then unable to release the work piece.

8. If the finger/work piece has become galled due to operational setting error, etc. open and close the fingers using the manual override or by removing the finger attachments.

If the manual override feature is to be used to remove a workpiece allow sufficient space to access the override. Do not apply excessive force to the manual override that could lead to damage and malfunction of the product.

<LEHZJ series only>

In the case of a gripper with dust covers, remove the encoder dust cover before operating the manual override.
Refit the encoder dust cover after using the manual override.

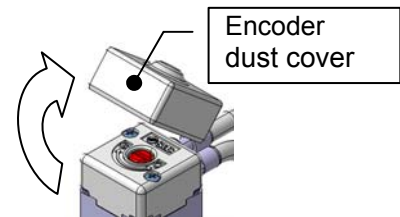

9. Self-lock mechanism

The product keeps a gripping force due to the self-lock mechanism in the lead screw. Also, it will not operate in opposite direction even when external force is applied during gripping.

<Type and cautions for stop>

1) All the power supplies to the controller are shut off.

When the power supply is turned on to restart operation, the controller will be initialized, and the product can drop a work piece due to a motor magnetic pole detective operation. (It means that there is finger motions of partial strokes by the phase detection of motor after power supply is turned on.) Remove the work piece before restarting operation.

2) “EMG (stop)” of the CN1 of the controller is shut off.

When using the stop switch on the teaching box;

a) In case both of [SVRE] and [SETON] are ON before stop,

[SVRE]; OFF / [SETON]: ON

b) How to restart operation

In this situation, since [SVRE] is on before stop, [SVRE] will be turned on automatically when stop is released, and operation can be restarted after that.

It is not necessary to remove a work piece beforehand because a motor magnetic pole detective operation will not occur.

c) Cautions

An alarm can take place when operation is restarted from stop.

Check that [SVRE] is turned on after the release of stop and restart operation.

3) “M24V (motor driving power supply)” of the CN1 of the controller is shut off.

- a) There will be no change in output conditions due to stop.
- b) How to restart operation

In this situation, operation can be restarted after stop is released.

It is not necessary to remove a work piece beforehand because a motor magnetic pole detective operation will not occur.

- c) Cautions

An alarm can take place when stop is activated during operation or operation is restarted from stop.

10. Return to origin

- 1) It is recommended to set the directions of return to origin and work piece gripping to the same direction.**

If they are set opposite, there can be backlash, which worsens the measurement accuracy significantly.

- 2) If the direction of return to origin is set to CW (Internal grip);**

If the return to origin is performed with the product only, there can be significant deviation between different actuators. Use a work piece to set return to origin.

- 3) If the return to position is performed by using a work piece;**

The stroke (operation range) will be shortened. Recheck the value of step data.

- 4) If basic parameters (Origin offset) are used;**

When the return to position is set with [Origin offset], it is necessary to change the current position of the product. Recheck the value of step data.

11. In pushing operation, set the product to a position of at least 0.5mm away from a work piece.

(This position is referred to as a gripping start position).

If the product is set to the same position as a work piece, the following alarm and unstable operation can occur.

a. “Posn failed” alarm

The product cannot reach a gripping start position due to the deviation of work pieces in width.

b. “Pushing ALM” alarm

The product is pushed back from a gripping start position after starting to grip.

c. “Err overflow” alarm

The displacement at the pushing start position exceeds the specified range.

8.4 Maintenance



Danger

- 1. When the product is to be removed, check that it is not gripping a work piece.**

There is a risk of dropping the work piece.



Caution

- 1. The dust cover on the gripper finger (LEHZJ series only) is a consumable item, replace the dust cover as and when it is necessary.**

Otherwise machining chips and fine particles may get into the product from the outside, leading to operation failure.





The dust cover on the gripper finger can be damaged if the finger attachment or the workpiece comes into contact with the dust cover during operation.

9. Troubleshooting

Alarms below are abstract of representative examples.

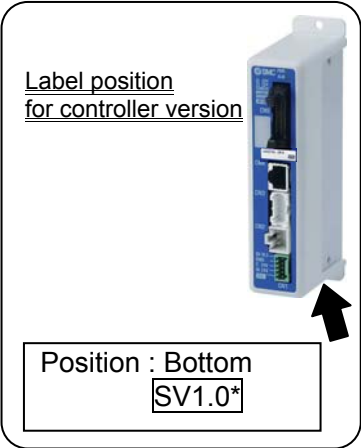
For other alarms, see operation manual of controller.



No.	Phenomenon	Cause	Countermeasure
1	Fail to operate / Initial stage	1) The cable is not connected or has been disconnected.	Confirm that the cable is connected correctly. /See 6. Wiring of cable on p. 39
	When power is supplied, alarm for "Phase Det ALM /code: 1-193" is generated. ↓ <Procedure of restart> "Turn the power supply off." ↓ "Turn the power supply on"	2) The load/resistance being applied to the actuator constantly exceeds the actuators specification.	Keep the load/resistance within the specified range. /See 2.1.1 Specifications on p.10 for LEHZ /See 2.2.1 Specifications on p.13 for LEHZJ /See 3.1 Specifications on p.17 for LEHF /See 4.1 Specifications on p.20 for LEHS
		3) The combination of the controller and the gripper is not correct.	The controller and gripper combination at the time of shipment should not be changed. /See 7.3⚠Caution(1) on p.41
		4) Excessive external force is being applied, (including vibration) or impact load.	Operate within the specified range. /See 2.1.1 Specifications on p.10 for LEHZ /See 2.2.1 Specifications on p.13 for LEHZJ /See 3.1 Specifications on p.17 for LEHF /See 4.1 Specifications on p.20 for LEHS Release the lead screw using the manual override. (All gripper models have a manual override) /See 8.3⚠Caution(8) on p.52
	Alarm for "Step data ALM1 /code:1-048" is generated ↓ <Procedure of restart> Input the "reset signal."	Setting condition for step data is not correct. < Correct set condition > (1)Area 1 < Area 2 (2) Trigger LV ≤ Pushing force (3) Pushing speed ≤ Speed (4) Pushing force ≥ Min. pushing force (40 %)	Review the content of step data. / Refer to the LEC controller operation manual.
	Alarm for "Servo off ALM /code: 1-098" is generated ↓ <Procedure of restart> Input the "reset signal."	Perform positioning, pushing operation, return to origin and jog operation during the "SVON":OFF.	Provide the operation instruction after confirming that the input signal [SVON] is ON and then the output signal [SVRE] is ON.
	Alarm for "Drive ALM /code: 1-099" is generated. ↓ <Procedure of restart> Input the "reset signal."	Perform positioning, pushing operation before the "return to origin".	Provide the operation instruction after confirming that the input signal [SETUP] is ON and then the output signal [SETON] is ON.
"ORIG direction" cannot be change.	After the "ORIG direction" is changed, the controller power supply has not been turned OFF.	Become effective after restarting the controller. /See "Initial setting for the ORIG parameters" on p.38	

No.	Phenomenon	Cause	Countermeasure
2	<p>Operation not completed / Operation continue</p> <p>Alarm for "Posn failed /code: 1-149" is generated.</p> <p style="text-align: center;">↓</p> <p><Procedure of restart> Controller version /SV1.0 or later 1. Input the "reset signal." →"SVRE": Automatically ON</p> <p>Controller version /SV0.6* or before 1. Input the "reset signal." →"SVRE": Automatically ON 2. Input the "setup signal." → Restart operation after the completion of the "return to origin".</p> <div style="border: 1px solid black; padding: 5px; margin-top: 10px;"> <p><u>Label position for controller version</u></p>  <p style="text-align: center;">Position : Bottom SV1.0*</p> </div>	1) The lead screw had galling due to excessive external force (including vibration) or impact.	Operate within the specified range /See 2.1.1 Specifications on p.10 for LEHZ /See 2.2.1 Specifications on p.13 for LEHZJ /See 3.1 Specifications on p.17 for LEHF /See 4.1 Specifications on p.20 for LEHS Release the lead screw using the manual override. (All gripper models have a manual override) /See 8.3  Caution (8) on p.52
		2) The Power supply does not have sufficient capacity.	Check the power consumption for each actuator and controller: If necessary replace the existing power supply with a power supply with sufficient capacity. /See 2.1.1 Specifications on p.10 for LEHZ /See 2.2.1 Specifications on p.13 for LEHZJ /See 3.1 Specifications on p.17 for LEHF /See 4.1 Specifications on p.20 for LEHS
		3) Load/resistance more than specified range is being applied to the actuator.	Use within specification range. /See 2.1.1 Specifications on p.10 for LEHZ /See 2.2.1 Specifications on p.13 for LEHZJ /See 3.1 Specifications on p.17 for LEHF /See 4.1 Specifications on p.20 for LEHS
		4) The Pushing operation is performed at the "Positioning operation" position.	Review the content of the step data. /See 8.3  Caution (2) on p.50
		5) For the Pushing operation: The position and the target start pushing position are not set correctly.	Check the step data. /See 8.3  Caution (11) on p.53
		6) The cable is not connected or has been disconnected.	Confirm that the cable is connected correctly. /See 6. Wiring of cable on p.39
		7) It was not the intended origin position because the gripper pinched the work-piece during the "return to origin".	Remove the work-piece and restart the return to the intended origin position.
		8) Wrong input [0] is input as the positioning force.	Check the step data. <Moving force> /See "Step data setting" on p.28,30
		9) The step data position is not changed correctly after the return to origin direction is changed.	Check the step data. <Position> /See "Step data setting" on p.28,30
		10) Because the operation of the step data is set to [INC/relative], the table comes into contact with an external object and does not move due to continuous operation.	Check the step data. <Position> /See "Step data setting" on p.28,30 Check if correct operation instruction is provided.

No.	Phenomenon	Cause	Countermeasure
2	Alarm for "Pushing ALM /code: 1-096" is generated. ↓ <Procedure of restart> Controller version /SV1.0 or later 1. Input the "reset signal." →"SVRE": Automatically ON Controller version /SV0.6* or before 1. Input the "reset signal." →"SVRE": Automatically ON 2. Input the "setup signal." → Restart operation after the completion of the"retun to origin".	1) For the Pushing operation, the position, target start-pushing position, is not set correctly.	Check the step data. /See 8.3▲Caution (11) on p.53
	Operation is not completed / Operation continue Alarm for "Over motor Vol /code: 1-145" is generated. ↓ <Procedure of restart> Controller version /SV1.0 or later 1. Input the "reset signal." →"SVRE": Automatically ON Controller version /SV0.6* or before 1. Input the "reset signal." →"SVRE": Automatically ON 2. Input the "setup signal." → Restart operation after the completion of the"retun to origin".	1) If the power supply is an "inrush-current restraining type", the alarm may be generated due to voltage drop. 2) The Power supply does not have sufficient capacity.	Replace the power supply with a non "inrush-current restraining type" power supply. / Refer to the LEC controller operation manual. Check the power consumption for each actuator and controller: If necessary replace the existing power supply with a power supply with sufficient capacity. /See 2.1.1 Specifications on p.10 for LEHZ /See 2.2.1 Specifications on p.13 for LEHZJ /See 3.1 Specifications on p.17 for LEHF /See 4.1 Specifications on p.20 for LEHS
	<div style="border: 1px solid black; padding: 10px;"> <p><u>Label position for controller version</u></p>  <p>Position : Bottom SV1.0*</p> </div>		

No.	Phenomenon	Cause	Countermeasure
2	Alarm for "Err overflow /code: 1-196" is generated. ↓ <Procedure of restart> "Turn the power supply off." ↓ "Turn the power supply on"	1) The lead screw had galling due to excessive external force (including vibration) or impact.	Operate within the specified range /See 2.1.1 Specifications on p.10 for LEHZ /See 2.2.1 Specifications on p.13 for LEHZJ /See 3.1 Specifications on p.17 for LEHF /See 4.1 Specifications on p.20 for LEHS Release the lead screw using the manual override. (All gripper models have a manual override) /See 8.3⚠Caution (8) on p.52
		2) The Power supply does not have sufficient capacity.	Check the power consumption for each actuator and controller: If necessary replace the existing power supply with a power supply with sufficient capacity. /See 2.1.1 Specifications on p.10 for LEHZ /See 2.2.1 Specifications on p.13 for LEHZJ /See 3.1 Specifications on p.17 for LEHF /See 4.1 Specifications on p.20 for LEHS
		3) Load/resistance more than specified range is being applied to the actuator.	Use within specification range. /See 2.1.1 Specifications on p.10 for LEHZ /See 2.2.1 Specifications on p.13 for LEHZJ /See 3.1 Specifications on p.17 for LEHF /See 4.1 Specifications on p.20 for LEHS
		4) The Pushing operation is performed at the "Positioning operation position"	Review the content of the step data. /See 8.3⚠Caution (2) on p.50
		5) For the Pushing operation: The position (the target start pushing position) is not set correctly.	Check the step data. /See 8.3⚠Caution (11) on p.53
		6) The cable is not connected or has been disconnected.	Confirm that the cable is connected correctly. /See 6. Wiring of cable on p.39
		7) It was not the intended origin position because the gripper pinched the work-piece during the "return to origin".	Remove the work-piece and restart the return to the intended origin position.
		8) Wrong input [0] is input as the positioning force.	Check the step data. <Moving force> /See "Step data setting" on p.28,30
		9) The step data position is not changed correctly after the return to origin direction is changed.	Check the step data. <Position> /See "Step data setting" on p.28,30
		10) Because the operation of the step data is set to [INC/relative], the table comes into contact with an external object and does not move due to continuous operation.	Check the step data. <Position> /See "Step data setting" on p.28,30 Check if correct operation instruction is provided.

No.	Phenomenon	Cause	Countermeasure
2	Operation not completed / During operation (Not always, but may happen occasionally) Alarm for "Step data ALM2 /code: 1-051" is generated. ↓ <Procedure of restart> Input the "reset" signal.	1) Command invalid (unregistered) step data.	Check if the step data is valid (registered).
		2) Different input signal to the expected step number is inputted to the controller, because of a too short an interval between the input signal of the "IN*" and the "Drive" or inputting the signals at the same time.	Add an interval of 15ms (the recommendation is 30ms) or more between the input signals. / See "Operating procedure input and output signals for each operation type" on P.34
		3) Different input signal to the expected step number is inputted to the controller, because the input signal time was too short.	Add an interval of 15ms (the recommendation is 30ms) or more between the input signals. / See "Operating procedure input and output signals for each operation type" on P.34
		4) Different input signal to the expected step number is inputted to the controller, caused by PLC or other device.	Check that the step number is inputted correctly for the required motion.
	- Operation completed by unexpected motion. - No alarm / During operation (Not always, but may happen occasionally)	1) Different input signal to the expected step number is inputted to the controller, because of a too short an interval between the input signal of the "IN*" and the "Drive" or inputting the signals at the same time.	Add an interval of 15ms (the recommendation is 30ms) or more between the input signals. / See "Operating procedure input and output signals for each operation type" on P.34 Note) Recommend to check the "OUT" output signal for more secure operation.
		2) Different input signal to the expected step number is inputted to the controller, because the input signal time was too short.	Add an interval of 15ms (the recommendation is 30ms) or more between the input signals. / See "Operating procedure input and output signals for each operation type" on P.34 Note) Recommend to check the "OUT" output signal for more secure operation.
		3) Different input signal to the expected step number is inputted to the controller, caused by PLC or other device.	Check that the step number is inputted correctly for the required motion. / See "Operating procedure input and output signals for each operation type" on P.34 Note) Recommend to check the "OUT" output signal for more secure operation.

No.	Phenomenon	Cause	Countermeasure
3	"Output signal" unstable the "INP output signal" turns "ON" before gripping the work piece.	1) "INP output signal" turns "ON" because the actual pushing force exceeds "TriggerLV".	Set the "Pushing force" and the "TriggerLV" within the specified range for the "Pushing speed" /See 8.3  Caution (5) on p.50
	"Output signal" is unstable when gripping the work piece. 1. INP output signal When gripping work piece: "ON" ↓ Momentary "OFF" ↓ "ON" 2. BUSY output signal When gripping work piece: "OFF" ↓ Momentary "ON" ↓ "OFF"	1) Situation of gripping the work-piece is unstable. Gripping the work piece in a position that allows the attachment to catch on the work piece. ↓ Work piece slipped. ↓ Re-holding the work piece.	Change the shape of the attachment to avoid being caught by the work-piece and to avoid slipping work-piece. Ex1) Attachment made by an elastic material. Ex2) Change the point of a lever where force is applied to the same axle. <If it is not possible to change the shape of attachment> The unstable gripping condition cannot be improved. <How to reduce the instability of the "Output signal"> 1. To reduce the influence when gripping the work piece. "Pushing force" = "TriggerLV" 2. Set the gripping force to be larger within the specified range. An unstable output signal may occur easily because of an external shock or vibration when the gripping force is set too low.
4	Unstable measurement accuracy	1) The origin returning direction and work piece gripping direction are different.	Set the directions to be identical. /See 8.3  Caution(10) on p.53
		2) Gripping speed is too fast. The accuracy becomes unstable due to inertia of the finger moving part.	Set the gripping speed as slow as possible.
5	Insufficient gripping force	1) The gripping point, overhang and external force are out of specification.	Check the catalog for the model selection.
		2) The load and resistance applied to the actuator are out of the specification.	Operate within the specified range. /See 2.1.1 Specifications on p.10 for LEHZ /See 2.2.1 Specifications on p.13 for LEHZJ /See 3.1 Specifications on p.17 for LEHF /See 4.1 Specifications on p.20 for LEHS
6	Damage	1) Abnormal external force (Including external force applied to the work piece after gripping work piece.)	Generation of interference of mechanism, eccentric load, excess load lead to cause deformation and damage of the actuator. Eliminate these

Revision history

NO.LEHZ-OM00201

Feb / 2009 1st printing

NO.LEHZ-OM00202

Mar / 2009 Revision

•Change How to Order

NO.LEHZ-OM00203

May / 2009 Revision

•Addition / LEHS Series (3 Finger Type)

NO.LEHZ-OM00204

Apr / 2010 Revision

•Addition / LEHZJ Series (With Dust Cover Type)

NO.LEHZ-OM00207

Sep / 2010 Revision

NO.LEHZ-OM00208

Mar / 2011 Revision

SMC Corporation

4-14-1, Sotokanda, Chiyoda-ku, Tokyo 101-0021 JAPAN

Tel: + 81 3 5207 8249 Fax: +81 3 5298 5362

URL <http://www.smcworld.com>

Note: Specifications are subject to change without prior notice and any obligation on the part of the manufacturer.

© 2010 SMC Corporation All Rights Reserved