



Operation Manual

PRODUCT NAME

Electric Actuator / Rod Type

《 AC Servo Motor 》

MODEL / Series

LEY Series

Applicable models: LEY□

LEY Series
(Rod type)

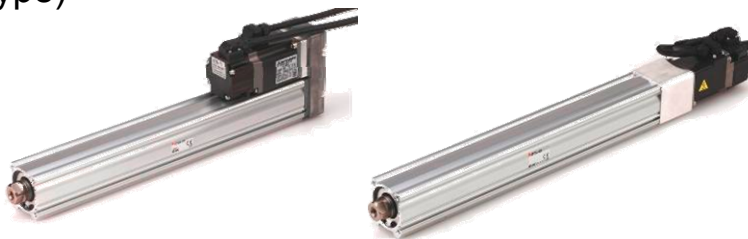

**AC Servo Motor
Controller
LECS Series**



LECSA
(Incremental
Encoder)



LECSB
(Absolute
Encoder)

SMC Corporation

Safety Instructions	2
1. Procedure before operation	4
1.1 Preparation.....	4
1.2 Startup	5
2. Rod type / LEY Series	6
2.1 Specification	6
2.2 How to Order.....	7
2.3 Construction	8
3. Product Outline	9
3.1 System construction	9
3.2 Function/Configuration.....	10
4. Wiring of cables / Common precautions	11
5. Electric actuators / Common precautions	12
5.1 Design and selection.....	12
5.2 Mounting	13
5.3 Handling	14
5.4 Operating environment	15
5.5 Maintenance.....	16
5.6 Precautions for actuator with lock.....	16
6. Electric actuators / Common precautions	17
6.1 Design and selection.....	17
6.2 Handling	17
6.3 Mounting	19
6.4 Precaution on maintenance.....	21
6.5 Replacement of belt	22
7. Troubleshooting	23
7.1 Alarms and Warning	23



LEY Series / Electric Rod type Safety Instructions

These safety instructions are intended to prevent hazardous situations and /or equipment damage. These instructions indicate the level of potential hazard with the labels of “Caution,” “Warning” or “Danger.” They are all important notes for safety and must be followed in addition to International Standards (ISO /IEC), Japan Industrial Standards (JIS)*1) and other safety regulations*2).

- *1) ISO 4414: Pneumatic fluid power -- General rules relating to systems
ISO 4413: Hydraulic fluid power -- General rules relating to systems
IEC 60204-1: Safety of machinery -- Electrical equipment of machines (Part 1: General requirements)
ISO 10218-1992: Manipulating industrial robots -- Safety
JIS B 8370: General rules for pneumatic equipment.
JIS B 8361: General rules for hydraulic equipment.
JIS B 9960-1: Safety of machinery -- Electrical equipment for machines. (Part 1: General requirements)
JIS B 8433-1993: Manipulating industrial robots - Safety. etc.

*2) Labor Safety and Sanitation Law, etc.



Caution

Caution indicates a hazard with a low level of risk which, if not avoided, could result in minor or moderate injury.



Warning

Warning indicates a hazard with a medium level of risk which, if not avoided, could result in death or serious injury.



Danger

Danger indicates a hazard with a high level of risk which, if not avoided, will result in death or serious injury.

Warning

1. The compatibility of the product is the responsibility of the person who designs the equipment or decides its specifications.

Since the product specified here is used under various operating conditions, its compatibility with specific equipment must be decided by the person who designs the equipment or decides its specifications based on necessary analysis and test results.

The expected performance and safety assurance of the equipment will be the responsibility of the person who has determined its compatibility with the product.

This person should also continuously review all specifications of the product referring to its latest catalog information, with a view to giving due consideration to any possibility of equipment failure when configuring the equipment.

2. Only personnel with appropriate training should operate machinery and equipment.

The product specified here may become unsafe if handled incorrectly.

The assembly, operation and maintenance of machines or equipment including our products must be performed by an operator who is appropriately trained and experienced.

3. Do not service or attempt to remove product and machinery /equipment until safety is confirmed.

The inspection and maintenance of machinery /equipment should only be performed after measures to prevent falling or runaway of the driven objects have been confirmed.

When the product is to be removed, confirm that the safety measures as mentioned above are implemented and the power from any appropriate source is cut, and read and understand the specific product precautions of all relevant products carefully.

Before machinery /equipment is restarted, take measures to prevent unexpected operation and malfunction.

4. Contact SMC beforehand and take special consideration of safety measures if the product is to be used in any of the following conditions.

1) Conditions and environments outside of the given specifications, or use outdoors or in a place exposed to direct sunlight.

2) Installation on equipment in conjunction with atomic energy, railways, air navigation, space, shipping, vehicles, military, medical treatment, combustion and recreation, or equipment in contact with food and beverages, emergency stop circuits, clutch and brake circuits in press applications, safety equipment or other applications unsuitable for the standard specifications described in the product catalog.

3) An application which could have negative effects on people, property, or animals requiring special safety analysis.

4) Use in an interlock circuit, which requires the provision of double interlock for possible failure by using a mechanical protective function, and periodical checks to confirm proper operation.



LEY Series / Electric Rod type Safety Instructions

Caution

The product is provided for use in manufacturing industries.

The product herein described is basically provided for peaceful use in manufacturing industries.

If considering using the product in other industries, consult SMC beforehand and exchange specifications or a contract if necessary.

If anything is unclear, contact your nearest sales branch.

Limited warranty and Disclaimer /Compliance Requirements

The product used is subject to the following “Limited warranty and Disclaimer” and “Compliance Requirements”.

Read and accept them before using the product.

Limited warranty and Disclaimer

The warranty period of the product is 1 year in service or 1.5 years after the product is delivered.*3) Also, the product may have specified durability, running distance or replacement parts. Please consult your nearest sales branch.

For any failure or damage reported within the warranty period which is clearly our responsibility, a replacement product or necessary parts will be provided.

This limited warranty applies only to our product independently, and not to any other damage incurred due to the failure of the product.

Prior to using SMC products, please read and understand the warranty terms and disclaimers noted in the specified catalog for the particular products.

***3) Vacuum pads are excluded from this 1 year warranty.**

A vacuum pad is a consumable part, so it is warranted for a year after it is delivered.

Also, even within the warranty period, the wear of a product due to the use of the vacuum pad or failure due to the deterioration of rubber material are not covered by the limited warranty.

Compliance Requirements

When the product is exported, strictly follow the laws required by the Ministry of Economy, Trade and Industry (Foreign Exchange and Foreign Trade Control Law).

1. Procedure before operation

1.1 Preparation

(1) Items to be prepared

Please check on the label, and the quantity of accessories, to confirm that it is the product that was ordered.

Table 1. Components

No.	Part name	Qty
(1)	Electric Actuator /LEY Series	1
(2)	Controller /LECSA Series or LECSB Series	1
(3)	Motor cable	1
(4)	Encoder cable	1
(5)	Lock cable	1
(6)	I/O Connector	1

Incremental Encoder (LECSA)

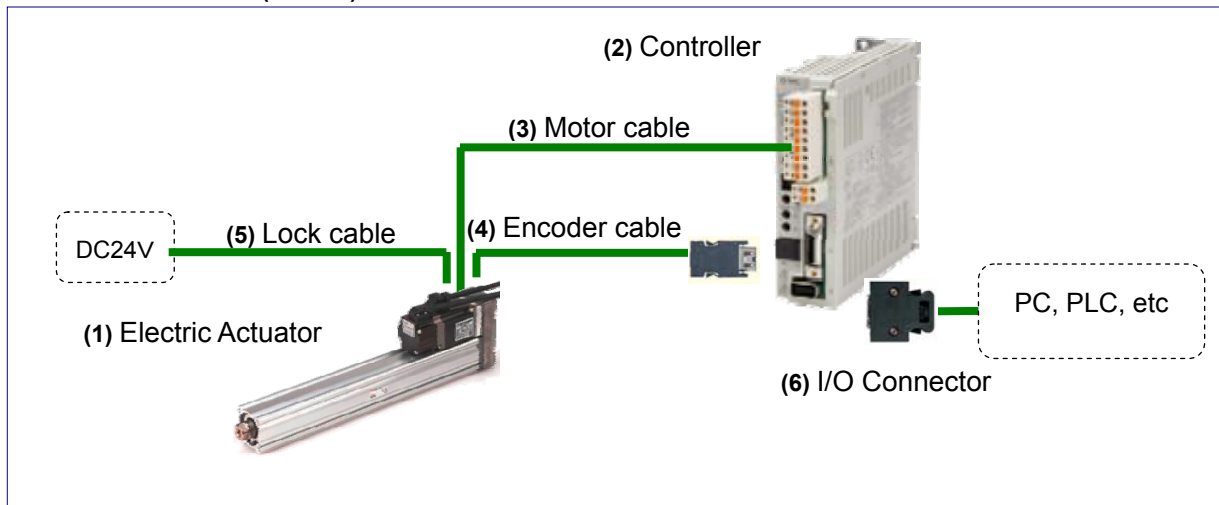

Absolute Encoder (LECSB)

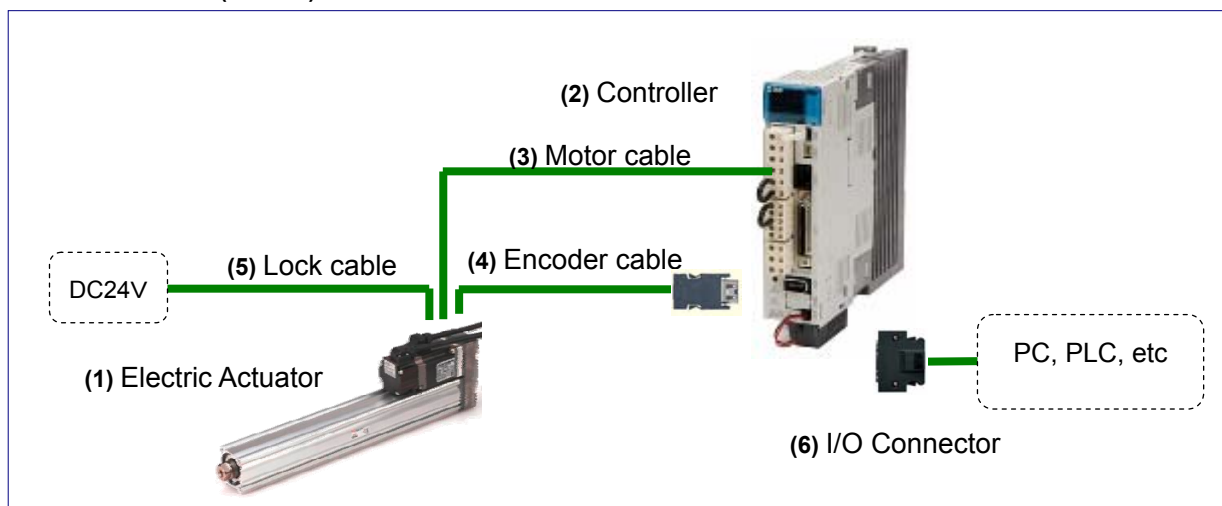

1.2 Startup

When switching the power on for the first time, follow the startup procedure below.
Refer to the "Controller operation manual" for wiring method and detailed procedure.

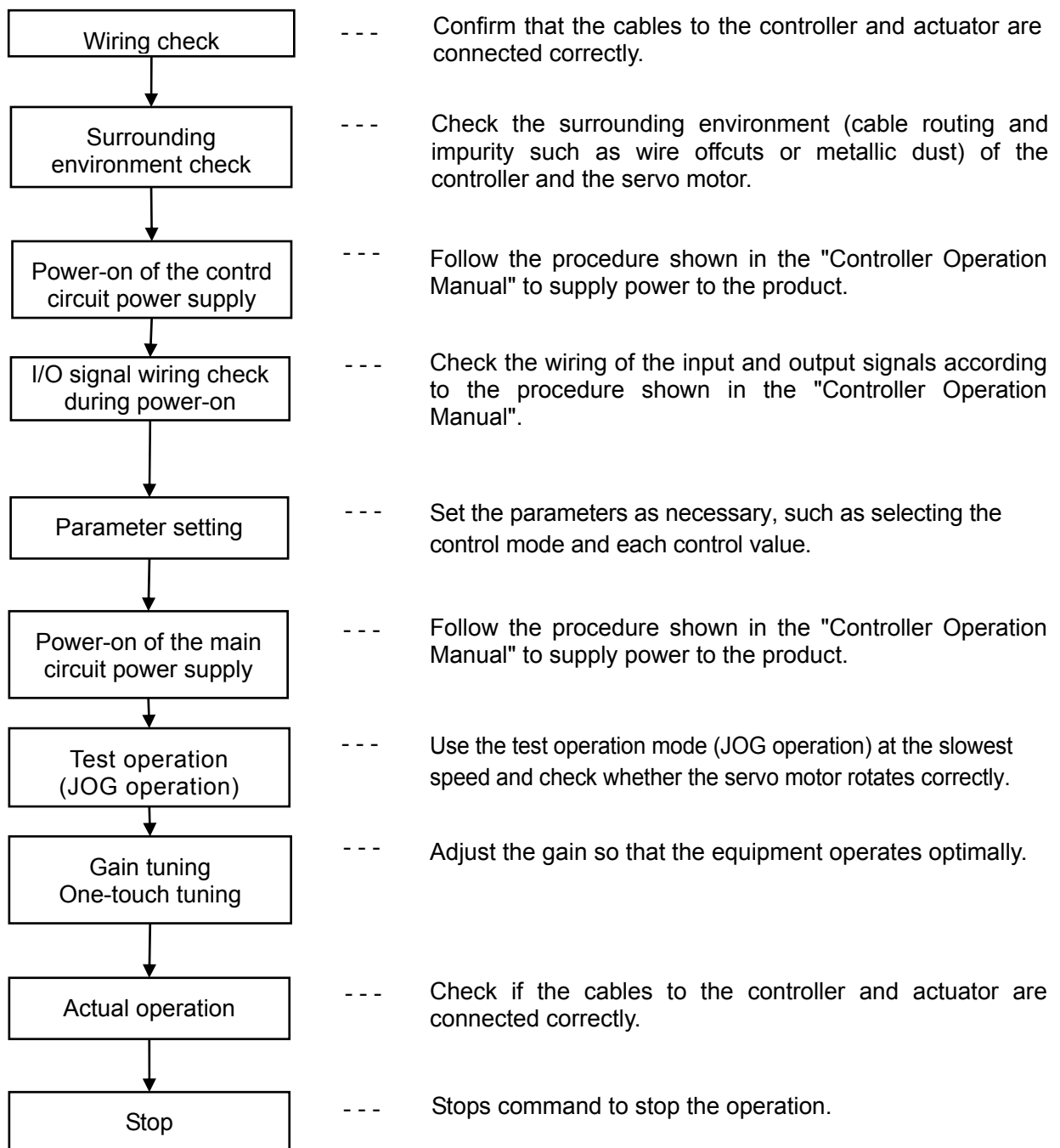

2. Rod type / LEY Series

2.1 Specification

Model		LEY25S* / LEY25DS*			LEY32S* (Parallel type)			LEY32DS* (In-line mounting type)				
Actuator specification	Stroke [mm] ^{Note1)}	30, 50, 100, 150, 200, 250, 300, 350, 400			30, 50, 100, 150, 200, 250, 300, 350, 400, 500			30, 50, 100, 150, 200, 250, 300, 350, 400, 500				
	Work load [kg]	Horizontal ^{Note2)}		18	50	50	30	60	60	30	60	60
		Vertical		8	16	30	9	19	37	12	24	46
	Pushing force [N] ^{Note3)} (Set value: 15 to 30%)		65~131	127~255	242~485	79~157	154~308	294~588	98~197	192~385	368~736	
	Maximum Speed ^{Note4)} [mm/s]	Range of stroke	to 300	900	450	225	1200	600	300	1000	500	250
			305 to 400	600	300	150						
			405 to 500	-	-	-	800	400	200	640	320	160
	Pushing speed [mm/s] ^{Note5)}		35 or less			30 or less			30 or less			
	acceleration/deceleration [mm/s ²]		5,000			5,000			5,000			
	Positioning repeatability [mm]		±0.02			±0.02			±0.02			
Lead [mm] (Including pulley ratio)		12	6	3	20	10	5	16	8	4		
Impact resistance/vibration Resistance [m/s ²] ^{Note6)}		50 / 20			50 / 20			50 / 20				
Drive method		Ball screw and Belt [1:1]/ Ball screw			Ball screw and Belt [1.25:1]			Ball screw				
Ball screw		Sliding bush (Piston rod part)			Sliding bush (Piston rod part)			Sliding bush (Piston rod part)				
Operating temperature range [°C]		5 to 40			5 to 40			5 to 40				
Operating humidity range [%RH]		90 or less (No condensation)			90 or less (No condensation)			90 or less (No condensation)				
Electric specification	Motor output/size	100W/□40			200W/□60			200W/□60				
	Type of Motor	AC servo motor (100/200VAC)			AC servo motor (100/200VAC)			AC servo motor (100/200VAC)				
	Encoder	[Type of Motor: S2,S3]: Incremental 17bit encoder (Resolution: 131072 p/rev) [Type of Moto: S6,S7]: Absolute 18bit encoder (Resolution: 262144 p/rev)										
Lock specification	Type ^{Note7)}	No excitation operating type										
	Holding force [N]	131	255	485	157	308	588	197	385	736		
	Power consumption [W] at 20 °C ^{Note8)}	6.3			7.9			7.9				
	Rated voltage [V]	24VDC ^U -10%										

Note 1) The middle stroke other than the above are produced upon receipt of order.

Note 2) The maximum value of the horizontal workload. (An external guide is necessary).

The actual workload will depend on the type of external guide.

Note 3) Thrust setting range when "pushing" operation in torque control mode, etc. Set it referring to the thrust conversion graph shown in the catalog as a guide.

Note 4) The allowable speed changes by the stroke.

Note 5) Allowable impact speed when "pushing" operation in torque control mode, etc.

Note 6) Impact resistance:

No malfunction occurred when the actuator was tested with a drop tester in both an axial direction and perpendicular direction to the lead screw. (The test was performed with the actuator in the initial state.)

Vibration resistance:

No malfunction occurred in a test ranging between 45 to 2000 Hz, when the actuator was tested in both an axial direction and a perpendicular direction to the lead screw. (The test was performed with the actuator in the initial state.)

Note 7) Only when the motor option, "with lock", is selected.

Note 8) For an actuator with lock, add the power consumption for the lock.

[Product Weight]

[kg]

Model		LEY25DS* (In-line mounting type)								LEY32DS* (In-line mounting type)											
Stroke [mm]		30	50	100	150	200	250	300	350	400	30	50	100	150	200	250	300	350	400	450	500
Type of Motor	Incremental Encoder	1.34	1.41	1.58	1.84	2.02	2.19	2.37	2.54	2.72	2.44	2.55	2.84	3.31	3.59	3.87	4.16	4.44	4.72	5.00	5.28
	Absolute Encoder	1.40	1.47	1.64	1.90	2.08	2.25	2.43	2.60	2.78	2.38	2.49	2.78	3.25	3.53	3.81	4.10	4.38	4.66	4.94	5.22
Model		LEY25S* (Parallel type)								LEY32S* (Parallel type)											
Stroke [mm]		30	50	100	150	200	250	300	350	400	30	50	100	150	200	250	300	350	400	450	500
Type of Motor	Incremental Encoder	1.31	1.38	1.55	1.81	1.99	2.16	2.34	2.51	2.69	2.42	2.53	2.82	3.29	3.57	3.85	4.14	4.42	4.70	4.98	5.26
	Absolute Encoder	1.37	1.44	1.61	1.87	2.05	2.22	2.40	2.57	2.75	2.36	2.47	2.76	3.23	3.51	3.79	4.08	4.36	4.64	4.92	5.20

[Additional weight for lock]

[kg]

		Size	
		25	32
Lock	Incremental Encoder	0.20	0.40
	Absolute Encoder	0.30	0.66
Rod end male thread	Part of male thread	0.03	0.03
	Nut	0.02	0.02
Foot style (Body mounting bolt is included, 2sets)		0.08	0.14
Rod side flange style (Body mounting bolt is included)		0.17	0.20
Motor side flange style (Body mounting bolt is included)			
Double clevis style (Clevis pin, Type C retaining ring for axis, Body mounting bolt is included)		0.16	0.22

2.2 How to Order

LEY25 □ S2 B - 100 □ □ □ - S2A1 □

Size

25
32

Motor mounting position

Nil	Top mounting type
R	Right side parallel type
L	Left side parallel type
D	In-line mounting type

Motor type

Type	Output [W]	Size	Applicable Controller
S2	100	25	A1,A2
S3		32	
S6	100	25	B1,B2
S7		32	

Lead [mm]

	LEY25□	LEY32□ ^{Note1)}
A	12	16 (20)
B	6	8 (10)
C	3	4 (5)

Note 1) Values in () are the actual lead which includes the pulley ratio when the product is size 32 top mounting type, right side parallel type or left side parallel type.

Motor option

Nil	None
B	With lock ^{Note2)}

Note 2) When "with lock type" is selected for top mounting type, right side parallel type or left side parallel type products, the motor body will stick out of the end of the body for product size 25 with strokes 30 or less. Check for interference with workpieces before selecting a model.

Stroke[mm]

30
5
500

* Refer to "Stroke" table

Rod end thread type

Nil	Rod end female thread
M	Rod end male thread (1 rod end nut is included)

Mounting style

Nil	Both ends tapped style(Standard)	F	Rod side flange style
U	Body bottom tapped style	G	Motor side flange style
L	Foot style	D	Double clevis style

* "Stroke" table

	30	50	100	150	200	250	300	350	400	450	500	Manufacturable range
LEY25	●	●	●	●	●	●	●	●	●	-	-	15~400
LEY32	●	●	●	●	●	●	●	●	●	●	●	20~500

Note) Consult SMC for intermediate strokes.

*When [Motor: In-line mounting type] specification is selected, [Foot style], [Motor side flange style], and [Double clevis style] specification cannot be selected.

*Mounting bracket is included, (but not assembled).

*When mounting styles are [Rod flange], [Head flange] or [Ends tapped] with one end fixed and mounted in a horizontal direction, use it within the following stroke.

●LEY25: 200 or less ●LEY32: 100 or less

*In case of [Double clevis], use the actuator within the following stroke limit.

●LEY25: 200 or less ●LEY32: 200 or less

*[Motor side flange style] for LEY32 is not available.

I/O connector

Nil	None
H	With connector

Controller type

	Applicable Controller	Power supply voltage
Nil	Without controller	
A1	LECSA1	100 to 120VAC
A2	LECSA2	200 to 230VAC
B1	LECSB1	100 to 120VAC
B2	LECSB2	200 to 230VAC

Cable length [m]^{Note3)}

Nil	Without cable
2	2
5	5
A	10

Note 3)The length of motor, encoder, and lock cables are same.

Cable type^{Note4)}

Nil	Without cable
S	Standard cable
R	Robotic cable (Long bending life)

Note 4) Motor cable and encoder cable are included. (If motor option "With lock" was selected, lock cable is included too.)

2.3 Construction

Top mounting type

(Right / Left side parallel type)

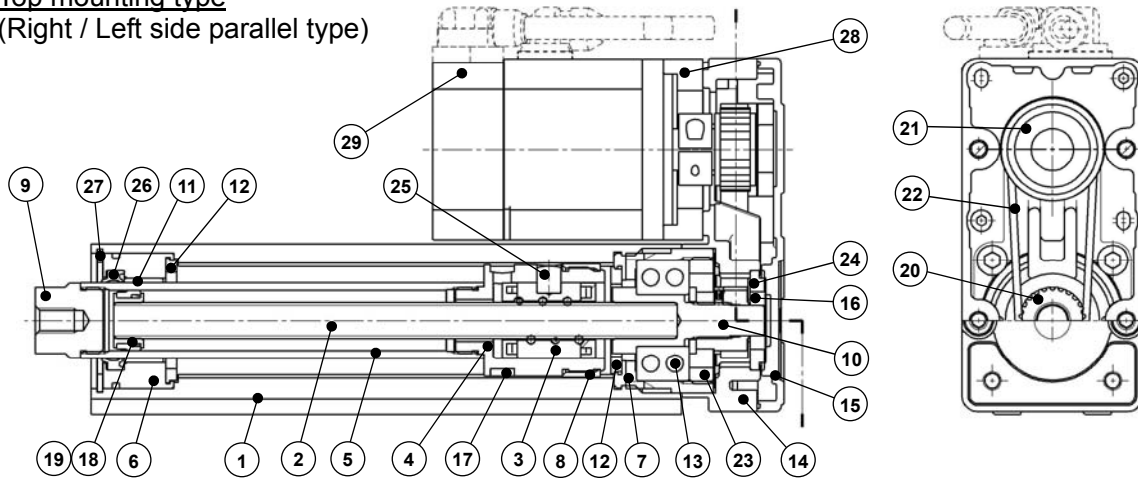

In-line mounting type

Rod end male thread

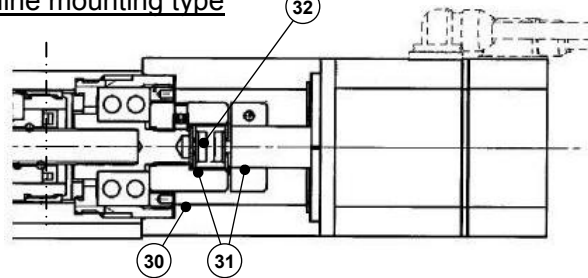
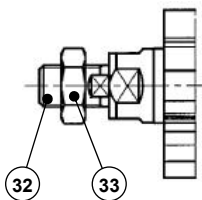

Parts list

No.	Part	Material	Remarks	No.	Part	Material	Remarks
1	Body	Aluminum alloy	Anodized	20	Pulley (For Screw shaft)	Aluminum alloy	
2	Ball screw shaft	Alloy steel		21	Pulley (For motor)	Aluminum alloy	
3	Ball screw nut	-		22	Belt	-	
4	Piston	Aluminum alloy		23	Bearing stopper	Aluminum alloy	
5	Piston rod	Stainless steel	Hard chrome anodized	24	Bearing support	Stainless steel	
6	Rod cover	Aluminum alloy		25	Parallel pin	Stainless steel	
7	housing	Aluminum alloy		26	Rod seal	NBR	
8	Rotation stopper	POM		27	Retaining ring	Steel for spring	
9	Socket	Free cutting carbon steels	Nickel plated	28	Motor adapter	Aluminum alloy	Anodized
10	Connected shaft	Free cutting carbon steels	Nickel plated	29	Motor	-	
11	Bushing	Lead bronze cast		30	Motor block	Aluminum alloy	Anodized
12	Bumper	Urethane		31	Hub	Aluminum alloy	
13	Bearing	-		32	Spider	Urethane	Spider
14	Pulley box	Aluminum die-cast	Non-Hexavalent chromated	33	Socket (male thread)	Free cutting carbon steels	Nickel plated
15	Pulley plate	Aluminum die-cast	Non-Hexavalent chromated	34	Nut	Alloy steel	
16	Bearing	-					
17	Magnet	-					
18	Wear ring holder	Stainless steel	Only stroke 101mm or more				
19	Wear ring	POM	Only stroke 101mm or more				

Mounting bracket part number

Size	Foot	Flange	Double clevis
25	LEY-L025	LEY-F025	LEY-D025
32	LEY-L032	LEY-F032	LEY-D032

/ When ordering foot bracket, order 2 pieces per actuator.

/ Parts belonging to each bracket are as follows.

Foot, Flange: Body mounting bolt.

Double clevis: Clevis pin, Type C retaining ring for axis, Body mounting bolt.

Maintenance parts / belt

Size	Part number
25	LE-D-2-2
32	LE-D-2-4

/ See 6.4 Precaution on maintenance on p.21

/ See 6.5 Replacement of belt on p.22

3. Product Outline

3.1 System construction

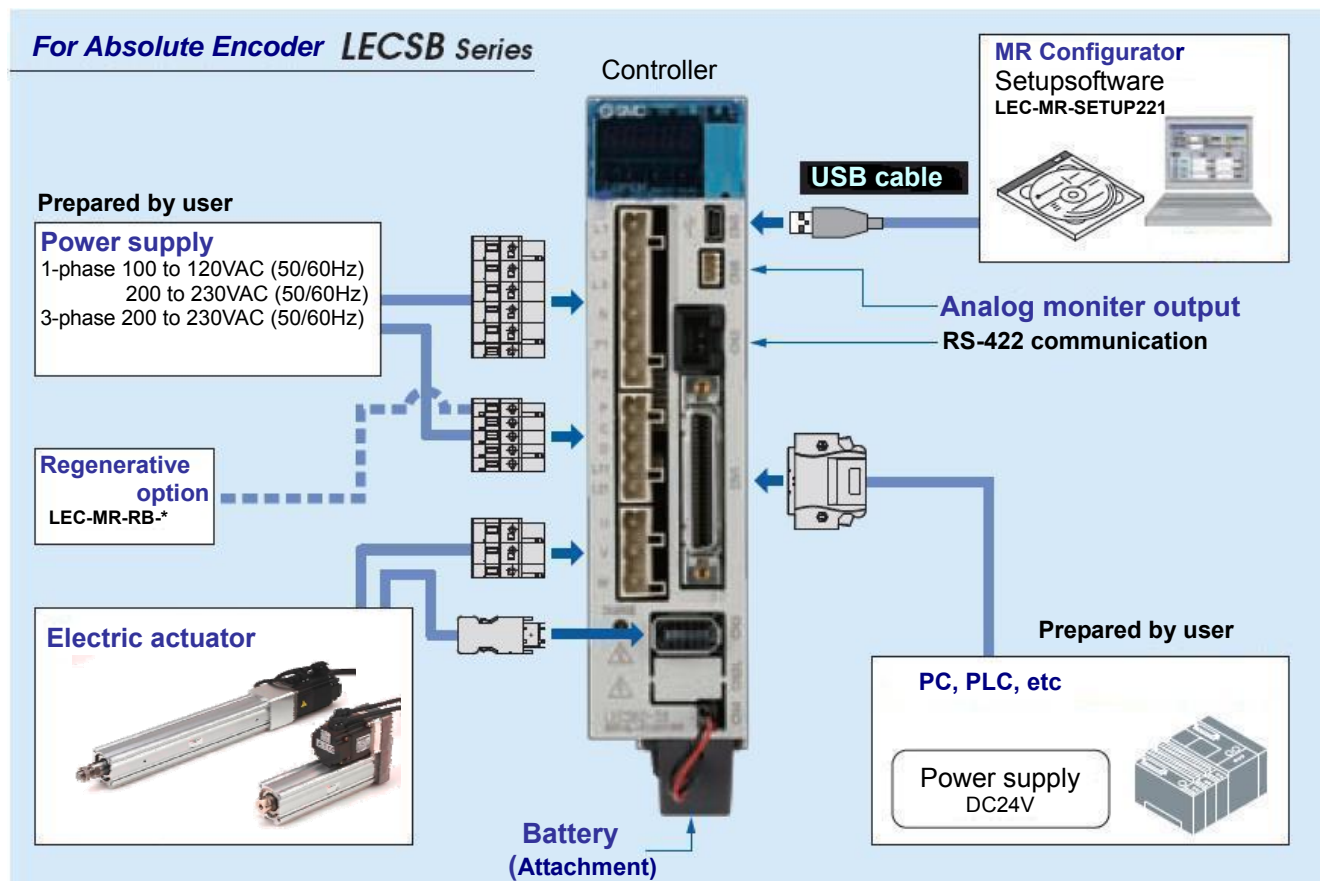
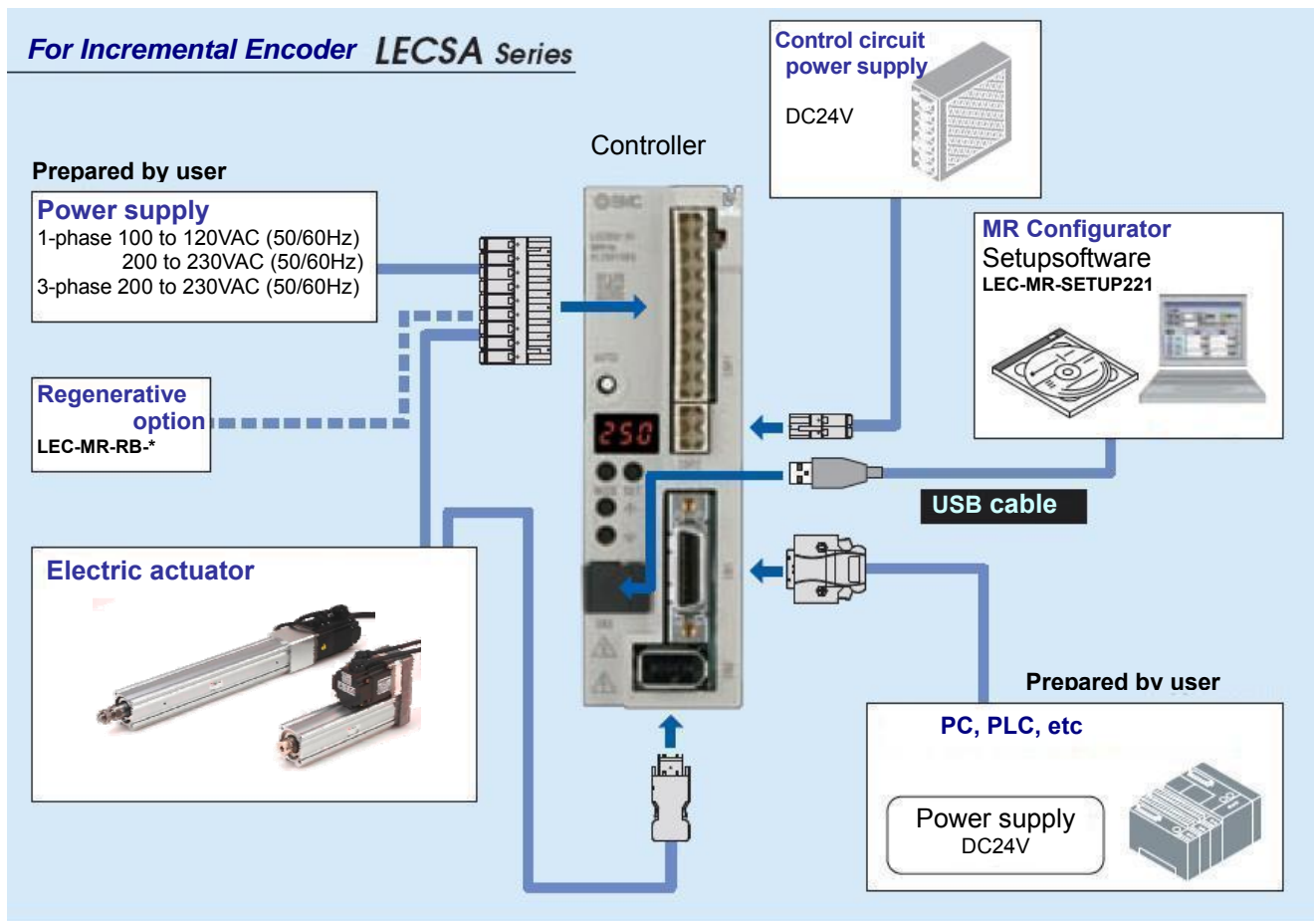

3.2 Function/Configuration

The following control mode can be selected for applicable actuators.
Please refer to the “Controller Operation Manual” about wiring and parameter setting.
Table. Applicable control mode. (○: Applicable)

Controller	Control mode ^{Note 1)} (Selected by parameter number PA1.)				
	Position control	Speed control	Torque control	Positioning	
				Point table method	Program method
LECSA (Incremental)	○	○ ^{Note 2)}	○ ^{Note 3)}	○ 3 Points (Max. 7 Points) ^{Note 4)}	○ 4 Programs (Max. 8 Programs) ^{Note4) 5)}
LECSB (Absolute)	○	○	○		
Command method	[Pulse train]	[ON/OFF Signal]	[ON/OFF Signal]	[ON/OFF Signal]	[ON/OFF Signal]
Operation method	Positioning operation	Setting speed operation	Setting torque operation	Positioning operation by point table No. setting	Positioning operation by program setting

Note 1 The control change mode cannot be used.

Note 2 Make the moving range limitation by external sensor etc to avoid actuator hitting to the work piece or stroke end.

Note 3 When using the pushing operation, the following parameter should be set.

If not, it will cause malfunction.

- LECSA: The value of the parameter value [PC12] “Internal torque command” should be 30% or less.
- LECSB: The value of the parameter value [PC13] “Analog torque maximum output command” should be 30% or less.

(30% = Maximum pushing force of the product.)

Note 4 To set the maximum value for the each method, it is necessary to change the setting.

Please refer “Controller Operation Manual”.

Note 5 The MR Configurator is necessary to control by the program method.

Please prepare separately.

- MR Configurator (Setup software Japanese version) / LEC-MR-STUP□□□
Please refer to "LECSA(11.4 MR Configurator)" for the system requirements of MR Configurator (setup software Japanese version).
MR Configurator (setup software English version), contact your nearest sales branch.

- USB cable for setup software (3m) / LEC-MR-J3USB

4. Wiring of cables / Common precautions

Warning

1. **Adjusting, mounting or wiring change should never be done before shutting off the power supply to the product.**
Electrical shock, malfunction and damaged can result.
2. **Never disassemble the cable. Use only specified cables.**
3. **Never connect or disconnect the cable or connector with power on.**

Caution

1. **Wire the connector securely. Do not apply any voltage to the terminals other than those specified in the product manual.**
2. **Wire the connector securely.**
Check for correct connector wiring and polarity.
3. **Take appropriate measures against noise.**
Noise in a signal line may cause malfunction. As a countermeasure, separate high voltage and low voltage cables, and shorten wiring lengths, etc.
4. **Do not route wires and cables together with power or high voltage cables.**
The product can malfunction due to interference of noise and surge voltage from power and high voltage cables to the signal line. Route the wires of the product separately from power or high voltage cables.
5. **Take care that actuator movement does not catch cables.**
6. **Operate with cables secured. Avoid bending cables at sharp angles where they enter the product.**
7. **Avoid twisting, folding, rotating or applying an external force to the cable.**
Risk of electric shock, wire break, contact failure and loss of control for the product can happen.
8. **Select “Robotic type cables” in case of inflecting cable(encoder/motor/rock) repeatedly.**
Refer to the “Controller operation manual” for the bending life of the bending radius of the cable.
9. **Confirm proper wiring of the product.**
Poor insulation (interference with other circuits, poor insulation between terminals and etc.) can apply excessive voltage or current to the product causing damage.

[Transportation]

Caution

1. **Do not carry or swing the product by the cable**

5. Electric actuators / Common precautions

5.1 Design and selection

Warning

Be sure to read the Operation Manual (this manual and the one for the controller: LEC series).

Handling or usage/operation other than that specified in the Operation Manual may lead to breakage and operation failure of the product.

Any damage attributed to the use beyond the specifications is not guaranteed.

2. There is a possibility of dangerous sudden action by the product if sliding parts of machinery are twisted due to external forces etc.

In such cases, human injury may occur, such as by catching hands or feet in the machinery, or damage to the machinery itself may occur. Design the machinery should be designed to avoid such dangers.

3. A protective cover is recommended to minimize the risk of personal injury.

If a driven object and moving parts of the product are in close proximity, personal injury may occur. Design the system to avoid contact with the human body.

4. Securely tighten all stationary parts and connected parts so that they will not become loose.

When the product operates with high frequency or is installed where there is a lot of vibration, ensure that all parts remain secure.

5. Consider a possible loss of power source.

Take measures to prevent injury and equipment damage even in the case of a power source failure.

6. Consider behavior of emergency stop of whole system.

Design the system so that human injury and/or damage to machinery and equipment will not be caused, when it is stopped by a safety device for abnormal conditions such as a power outage or a manual emergency stop of whole system.

7. Consider the action when operation is restarted after an emergency stop or abnormal stop of whole system.

Design the system so that human injury or equipment damage will not occur upon restart of operation of whole system.

8. Disassembly and modification is prohibited

Do not modify or reconstruct (including additional machining) the product. An injury or failure can result.

9. When using it for vertical application, it is necessary to build in a safety device.

The rod may fall due to the weight of work. The safety device should not interfere with normal operation of the machine.

Caution

1. Operate within the limits of the maximum usable stroke.

The product will be damaged if it is used with the stroke which is over the maximum stroke. Refer to the specifications of the product.

2. When the product repeatedly cycles with partial strokes, operate it at a full stroke at least once every 10 strokes.

Otherwise, lubrication can run out.

3. Do not use the product in applications where excessive external force or impact force is applied to it.

The product can be damaged.

4. Refer to a common auto switch /matter (Best Pneumatics No 2) when an auto switch is built in and used.

5.2 Mounting

Warning

1. **Install and operate the product only after reading the Operation Manual carefully and understanding its contents. Keep the manual in a safe place for future reference.**

2. **Observe the tightening torque for screws.**

Tighten the screws to the recommended torque for mounting the product.

3. **Do not make any alterations to this product.**

Alterations made to this product may lead to a loss of durability and damage to the product, which can lead to human injury and damage to other equipment and machinery.

4. **When using external guide, the guide axis should be parallel to the actuator axis.**

There will be damage/excessive wear on the lead screw if the external guide is not parallel.

5. **When an external guide is used, connect the moving parts of the product and the load in such a way that there is no interference at any point within the stroke.**

Do not scratch or dent the sliding parts of the product tube or piston rod etc., by striking or grasping them with other objects. Components are manufactured to precise tolerances, so that even a slight deformation may cause faulty operation.

6. **Prevent the seizure of rotating parts.**

Prevent the seizure of rotating parts (pins, etc.) by applying grease.

7. **Do not use the product until you verify that the equipment can operate properly.**

After mounting or repair, connect the power supply to the product and perform appropriate functional inspections to check it is mounted properly.

8. **Cantilever**

When the actuator is operated at high speed while it is fixed at one end and free at the other end (flange type, foot type, double clevis type, direct mount type), a bending moment may act on the actuator due to vibration generated at the stroke end, which can damage the actuator. In such a case, install a support bracket to suppress the vibration of the actuator body or reduce the speed so that the actuator does not vibrate. Use a support bracket also when moving the actuator body or when a long stroke actuator is mounted horizontally and fixed at one end.

9. **When attaching work piece, do not apply strong impact or large moment.**

If an external force over the allowable moment is applied, it may cause looseness in the guide unit, an increase in sliding resistance or other problems.

10. **Maintenance space**

Allow sufficient space for maintenance and inspection.

5.3 Handling

Warning

1. **If abnormal heating, smoking or fire, etc., occurs in the product, immediately shut off the power supply.**
2. **Immediately stop operation if abnormal operation noise or vibration occurs.**
If abnormal operation noise or vibration occurs, the product may have been mounted incorrectly. Unless operation of the product is stopped for inspection, the product can be seriously damaged.
3. **Never touch the rotating part of the motor or moving part of the actuator while in operation.**
4. **When installing, adjusting, inspecting or performing maintenance on the product, controller and related equipment, be sure to shut off the power supply to them. Then, lock it so that no one other than the person working can turn the power on, or implement measures such as a safety plug.**

Caution

1. **Keep the controller and product combined as delivered for use.**
The product is set in parameters for shipment. If it is combined with a different parameter, failure can result.
2. **Check the product for the following points before operation.**
 - a) Damage to power supply line and signal line.
 - b) Looseness of the connector to each power line and signal line.
 - c) Looseness of the actuator /cylinder and controller /driver mounting
 - d) Abnormal operation
 - e) Emergency stop of the total system
3. **When more than one person is performing work, decide on the procedures, signals, measures and resolution for abnormal conditions before beginning the work. Also, designate a person to supervise work other than those performing work.**
4. **Actual speed of the product will be changed by the workload.**
Before selecting a product, check the catalog for the instructions regarding selection and specifications.
5. **Do not apply a load, impact or resistance in addition to a transferred load during return to origin.**
In the case of the return to origin by pushing force, additional force will cause displacement of the origin position since it is based on detected motor torque.
6. **Do not remove the nameplate.**
7. **Operation test should be done by low speed. Start operation by predefined speed after confirming there is no trouble.**

[Ground]

Warning

1. **Please do the earth construction surely.**
2. **Please refer to the controller manual for the grounding procedure and notes.**

[Unpackaging]

Caution

① Check the received product is as ordered.

If the different product is installed from the one ordered, injury or damage can result.

5.4 Operating environment

Warning

Avoid use in the following environments.

- a. Locations where a large amount of dusts and cutting chips are airborne.
 - b. Locations where the ambient temperature is outside the range of the temperature specification (refer to specifications).
 - c. Locations where the ambient humidity is outside the range of the humidity specification (refer to specifications).
 - d. Locations where corrosive gas, flammable gas, sea water, water and steam are present.
 - e. Locations where strong magnetic or electric fields are generated.
 - f. Locations where direct vibration or impact is applied to the product.
 - g. Areas that are dusty, or are exposed to splashes of water and oil drops.
 - h. Areas exposed to direct sunlight (ultraviolet ray).
2. **Do not use in an environment where the product is directly exposed to liquid, such as cutting oils.**
If cutting oils, coolant or oil mist contaminates the product, failure or increased sliding resistance can result.
 3. **Install a protective cover when the product is used in an environment directly exposed to foreign matters such as dust, cutting chips and spatter.**
Play or increased sliding resistance can result.
 4. **Shade the sunlight in the place where the product is applied with direct sunshine.**
 5. **Shield the product if there is a heat source nearby.**
When there is a heat source surrounding the product, the radiated heat from the heat source can increase the temperature of the product beyond the operating temperature range. Protect it with a cover, etc.
 6. **Grease oil can be decreased due to external environment and operating conditions, and it deteriorates lubrication performance to shorten the life of the product.**

[Storage]

Warning

Do not store the product in a place in direct contact with rain or water drops or is exposed to harmful gas or liquid.

2. **Store in an area that is shaded from direct sunlight and has a temperature and humidity within the specified range (-10°C to 60°C and 90%RH or less No condensation or freezing).**
3. **Do not apply vibration and impact to the product during storage.**

5.5 Maintenance

Warning

1. **Do not disassemble or repair the product.**

Fire or electric shock can result.

2. **Before modifying or checking the wiring, the voltage should be checked with a tester 5 minutes after the power supply is turned off.**

Electrical shock can result.

Caution

1. **Maintenance should be performed according to the procedure indicated in the Operating Manual.**

Incorrect handling can cause an injury, damage or malfunction of equipment and machinery.

2. **Removal of product**

When equipment is serviced, first confirm that measures are in place to prevent dropping of work pieces and run-away of equipment, etc, and then cut the power supply to the system. When machinery is restarted, check that operation is normal with actuators in the proper positions.

[Lubrication]

Caution

1. **The product has been lubricated for life at manufacturer, and does not require lubrication in service.**

Contact SMC if lubrication will be applied.

5.6 Precautions for actuator with lock

Warning

1. **Do not use the lock as a safety lock or a control that requires a locking force.**
The lock used for the product with a lock is designed to prevent dropping of work piece.
2. **For vertical mounting, use the product with a lock.**
If the product is not equipped with a lock, the product will move and drop the work piece when the power is removed.
3. **"Measures against drops" means preventing a work piece from dropping due to its weight when the product operation is stopped and the power supply is turned off.**
4. **Do not apply an impact load or strong vibration while the lock is activated.**
If an external impact load or strong vibration is applied to the product, the lock will lose its holding force and damage to the sliding part of the lock or reduced lifetime can result. The same situations will happen when the lock slips due to a force higher than its holding force, as this will accelerate the wear to the lock.
5. **Do not apply liquid or oil and grease to the lock or its surrounding.**
When liquid or oil and grease is applied to the sliding part of the lock, its holding force will be reduced significantly.
6. **Take measures against drops and check that safety is assured before mounting, adjustment and inspection of the product.**
If the lock is released with the product mounted vertically, a work piece can drop due to its weight.

6. Electric actuators / Common precautions

6.1 Design and selection

Warning

- 1. Do not apply a load in excess of the actuator specification.**
A product should be selected based on the maximum work load and allowable moment.
If the product is used outside of the operating specification, eccentric load applied to the guide will become excessive and have adverse effects such as creating play at the guide, reduced accuracy and reduced product life.
- 2. Do not use the product in applications where excessive external force or impact force is applied to it.**
This can lead to premature failure of the product..
- 3. Do not use as a stopper application.**

6.2 Handling

Caution

- 1. For pushing operation, make sure to set it to "torque control mode", and operate within the "pushing speed" range of each model.**
Do not hit the workpiece or the stroke end with the piston in the "position control mode", "speed control mode" or "positioning mode". The lead screw, bearing and internal stopper may be damaged, causing malfunction.
- 2. Make sure to set the internal torque command (LECSA) or analog torque command maximum output value (LECSB) to 30 % or less when operating the product in the "torque control mode".**
It may lead to breakage and malfunction.
- 3. Normal/reverse torque limit value is set to 100 % (3 times as much as the motor rated torque) as a default.**
It is the maximum torque (the limit value) in the "position control mode", "speed control mode" or "positioning mode". When the product is operated with a smaller value than the default, acceleration when driving can decrease. Set it upon confirmation with the actual equipment used.
- 4. The maximum speed of this actuator varies depending on the stroke of the product.**
When selecting a product, check the catalog for the model selection.
- 5. Do not apply a load, impact or resistance in addition to a transferred load during return to origin.**
Otherwise, the origin can be displaced since it is based on detected motor torque.
- 6. Do not scratch or gouge the sliding parts of the piston rod, by striking or grasping them with other objects.**
Piston rod is manufactured to precise tolerances, so that even a slight deformation may cause malfunction.
- 7. Please connect it so that the impact and load may not be added to the rod from the side when external guide is used.**
- 8. Please do not operate body itself by the piston rod fixing.**
An excessive load joins the piston rod, and it causes defective operation and the longevity decrease.
- 9. When the actuator is operated at high speed while it is fixed at one end and free at the other end (flange type, foot type, double clevis type, direct mount type), a bending moment may act on the actuator due to vibration generated at the stroke end, which can damage the actuator. In such a case, install a support bracket to suppress the vibration of the actuator body or reduce the speed so that the actuator does not vibrate.**
Use a support bracket also when moving the actuator body or when a long stroke actuator is mounted horizontally and fixed at one end.

10. Avoid using the electric actuator in such a way that rotational torque would be applied to the piston rod.

If rotational torque is applied, the non-rotating guide will become deformed, thus affecting the non-rotating accuracy.

Refer to the table below for the approximate values of the allowable range of rotational torque.

Allowable rotational torque (Nm or less)	LEY25**	LEY32**
	1.1	1.4

To screw a bracket or a nut onto the threaded portion at the tip of the piston rod, make sure to retract the piston rod entirely, and place a wrench over the flat portion of the rod that protrudes.

Tighten it by giving consideration to prevent the tightening torque from being applied to the non-rotating guide.

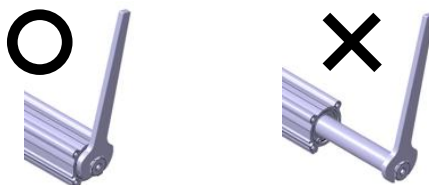

6.3 Mounting

⚠ Caution

1. Fix 'Socket' square width across flats in the piston rod point with the spanner etc. , prevent the piston rod from rotating, and tighten the screw tightening when work piece or jig, etc. are installed properly by the torque value within the range of the limitation.

It causes the abnormal reaction of an auto switch, the space of an internal guide, and an increase of the sliding resistance, etc..

2. When mounting the workpiece or other device to the actuator tighten the fixing screws with adequate torque within the specified torque range.

Tightening the screws with a higher torque than the maximum may cause malfunction, whilst tightening with a lower torque can cause the displacement of the mounting position or in extreme conditions detaching of the work piece.

<LEY series>

Work fixed / Rod end female thread

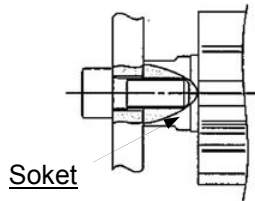

Model	Bolt	Max. tightening torque [Nm]	Max.thread depth [mm]	Scket width across flats [mm]
LEY25	M8x1.25	12.5	13	17
LEY32	M8x1.25	12.5	13	22

Work fixed / Rod end male thread

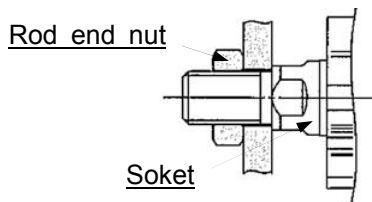

Model	Thread size	Max. tightening torque [Nm]	Max.thread depth [mm]	Scket width across flats [mm]
LEY25	M14x1.5	65	20.5	17
LEY32	M14x1.5	65	20.5	22

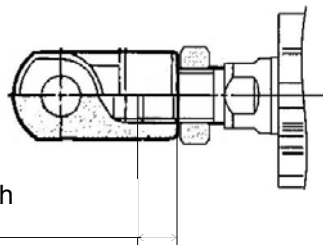

Thread depth of bracket

Model	Rod end nut		thread depth [mm]
	Width across flats [mm]	Length [mm]	
LEY25	22	8	8 or more
LEY32	22	8	8 or more

Mounting / Body bottom tapped style (When "Body bottom tappde" is selected)

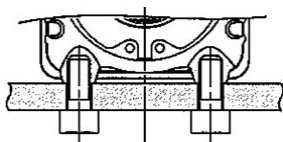

Model	Bolt	Max. tightening torque [Nm]	Max.thread depth [mm]
LEY25	M5x0.8	3.0	6.5
LEY32	M6x1.0	5.2	8.8

Mounting / Rod side•Head side tapped style

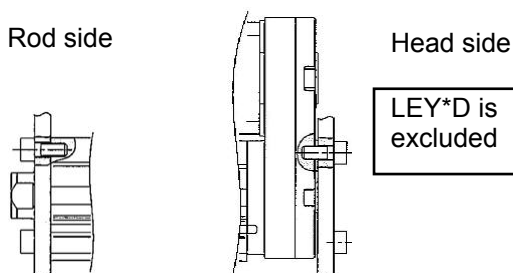

Model	Bolt	Max. tightening torque [Nm]	Max.thread depth [mm]
LEY25	M5x0.8	3.0	8
LEY32	M6x1.0	5.2	10

3. Keep the flatness of the mounting surface within the following ranges when mounting the actuator body and work piece.

Insufficient flatness of the work piece or the surface onto which the actuator body is to be mounted can cause increased sliding resistance.

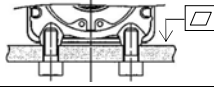
Model	Mounting part	Flatness
LEY*	Actuator body /Body bottom tapped style 	0.1mm or less

6.4 Precaution on maintenance

⚠ Caution

1. Cut the power supply during maintenance and replacement of the product.

[Maintenance frequency]

Preform maintenance according to the table below.

	Appearance check	Check belt
Inspection before daily operation	○	
Inspection every six months *	○	○
Inspection every 250km *	○	○
Inspection are every five million times *	○	○

*Either of inspection early time is selected.

[Items for visual appearance check]

1. Loose set screws, abnormal dirt.
2. Check of flaw and cable joint
3. Vibration, noise.

[Belt replacement] (Motor mounting position : only parallel type)

It is recommended that the belt be replaced after 2 years or after following actuator movement distance. The life of the belt may be reduced due to operating conditions and the environment. Check the belt regularly as shown in “maintenance frequency” and replace belt if any abnormality is detected.

Model	Distance	Model	Distance
LEY25*A	2,500km	LEY32*A	4,000km
LEY25*B	1,200km	LEY32*B	2,000km
LEY25*C	600km	LEY32*C	1,000km

[Items for belt check]

Stop operation immediately and replace the belt when belt appear to be like photos below.

a . Tooth shape canvas is worn out

Canvas fiber becomes fuzzy. Rubber is removed and the fiber becomes whitish. Lines of fibers become unclear.



Teeth become fuzzy

b . Peeling off or wearing of the side of the belt

Belt corner becomes round and frayed thread sticks out.

c . Belt partially cut

Belt is partially cut. Foreign matter caught in teeth other than cut part causes flaw.



d . Vertical line of belt teeth

Flaw which is made when the belt runs on the flange.

e . Rubber back of the belt is softened and sticky

f . Crack on the back of the belt



6.5 Replacement of belt

1. After Bolt is removed, "Pulley plate" is removed.

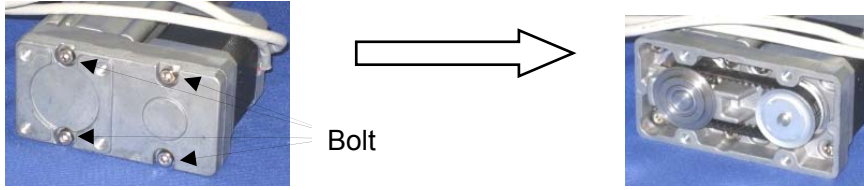

2. The bolt that is the fixation of "Motor" is loosened (To extent in which the slide can be done), and "Bearing support" is removed, and "Belt" is removed.

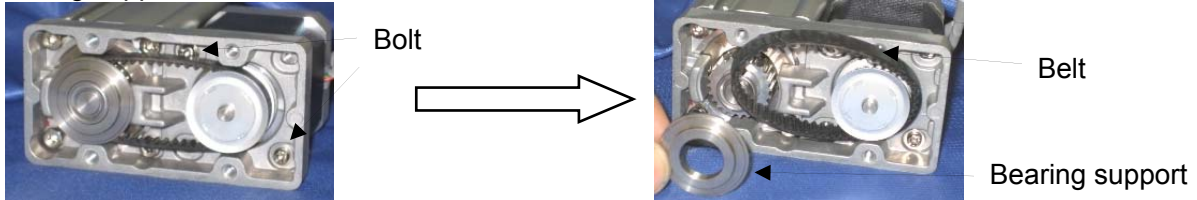

3. After "Belt" is installed, and the bearing support is obtained, the root of "Motor" is pulled in a string or a long banding band. With tensile force adjusted, tighten the bolts which fix the actuator to the motor. (See the table below)

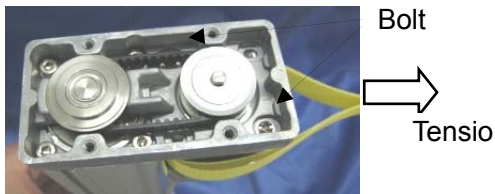

Size	Belt Part number	Belt tension (N)	Tightening torque (Nm)
LEY25	LE-D-2-2	19	0.63
LEY32	LE-D-2-4	30	1.5

*For LEY32: After the nut on Motor side is fixed by the spanner, it tightens a bolt.

5. "Pulley plate" is installed.

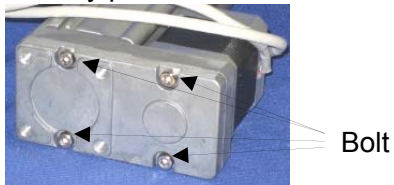

Size	Tightening torque (Nm)
LEY25	1.5
LEY32	5.2

7. Troubleshooting

7.1 Alarms and Warning

When a fault occurs during the operation, the corresponding alarm or warning is displayed. If any alarm or warning has occurred, refer to "Remedies for alarms/Remedies for warnings" in the "Controller Operation Manual" and take the appropriate action. After removing the cause of the alarm, the alarm can be deactivated in any of the methods marked ○ in the alarm deactivation column.

•Incremental Encoder (LECSA)

	Display	Name	Alarm deactivation		
			Power OFF→ON	Press "SET" on current alarm screen.	Alarm reset (RES)
Alarms	A.10	Undervoltage	○	○	○
	A.12	Memory error 1 (RAM)	○	-	-
	A.13	Clock error	○	-	-
	A.15	Memory error 2 (EEP-ROM)	○	-	-
	A.16	Encoder initial communication error1	○	-	-
	A.17	Board error	○	-	-
	A.19	Memory error 3 (Flash-ROM)	○	-	-
	A.1A	Motor combination error	○	-	-
	A.1C	Software combination error	○	-	-
	A.1E	Encoder initial communication error 2	○	-	-
	A.1F	Encoder initial communication error 3	○	-	-
	A.20	Encoder normal communication error 1	○	-	-
	A.21	Encoder normal communication error 2	○	-	-
	A.24	Main circuit error	○		
	A.30	Regenerative error	○(Note 1)	○(Note 1)	○(Note 1)
	A.31	Overspeed	○	○	○
	A.32	Overcurrent	○		
	A.33	Overvoltage	○	○	○
	A.35	Command frequency error	○	○	○
	A.37	Parameter error	○	-	-
	A.39	Program error	○	-	-
	A.45	Main circuit device overheat	○(Note 1)	○(Note 1)	○(Note 1)
	A.46	Servo motor overheat	○(Note 1)	○(Note 1)	○(Note 1)
	A.50	Overload 1	○(Note 1)	○(Note 1)	○(Note 1)
	A.51	Overload 2	○(Note 1)	○(Note 1)	○(Note 1)
	A.52	Error excessive	○	○	○
	A.61	Operation alarm	○	○	○
	A.8E	USB communication error	○	○	○
888	Watchdog	○	-	-	

	Display	Name
Warning	A.90	Home positioning incomplete warning
	A.91	Amplifier overheat warning
	A.96	Home position setting error
	A.97	Program operation disable
	A.98	Software limit warning
	A.99	Stroke limit warning
	A.E0	Excessive regeneration warning
	A.E1	Overload warning 1
	A.E6	Servo forced stop warning
	A.E9	Main circuit off warning
	A.EC	Overload warning 2
	A.ED	Output watt excess warning
	A.F0	Tough drive warning

Note 1. Deactivate the alarm about 30 minutes of cooling time after removing the cause of occurrence.

•Absolute Encoder(LECSB)

	Display	Name	Alarm deactivation		
			Power OFF→ON	Press "SET" on current alarm screen.	Alarm reset (RES)
Alarms	AL.10	Undervoltage	○	○	○
	AL.12	Memory error 1 (RAM)	○	-	-
	AL.13	Clock error	○	-	-
	AL.15	Memory error 2 (EEP-ROM)	○	-	-
	AL.16	Encoder error 1(At power on)	○	-	-
	AL.17	Board error	○	-	-
	AL.19	Memory error 3(Flash-ROM)	○	-	-
	AL.1A	Motor combination error	○	-	-
	AL.20	Encoder error 2(during runtime)	○	-	-
	AL.21	Encoder error 3(during runtime)	○	-	-
	AL.24	Main circuit error	○	○	○
	AL.25	Absolute position erase	○	-	-
	AL.30	Regenerative error	○(Note 1)	○(Note 1)	○(Note 1)
	AL.31	Overspeed	○	○	○
	AL.32	Overcurrent	○	-	-
	AL.33	Overvoltage	○	○	○
	AL.35	Command pulse frequency alarm	○	○	○
	AL.37	Parameter error	○	-	-
	AL.45	Main circuit device overheat	○(Note 1)	○(Note 1)	○(Note 1)
	AL.46	Servo motor overheat	○(Note 1)	○(Note 1)	○(Note 1)
	AL.47	Cooling fan alarm	○	-	-
	AL.50	Overload 1	○(Note 1)	○(Note 1)	○(Note 1)
	AL.51	Overload 2	○(Note 1)	○(Note 1)	○(Note 1)
	AL.52	Error excessive	○	○	○
AL.8A	Serial communication time-out	○	○	○	
AL.8E	Serial communication error	○	○	○	
88888	Watchdog	○	-	-	

	Display	Name
Warning	A.92	Battery cable disconnection warning
	A.96	Home position setting error
	A.99	Stroke limit warning
	A.9F	Battery warning
	A.E0	Excessive regeneration warning
	A.E1	Overload warning 1
	A.E3	Absolute position counter warning
	A.E5	ABS time-out warning
	A.E6	Servo emergency stop warning
	A.E8	Cooling fan speed reduction warning
	A.E9	Main circuit off warning
	A.EA	ABS servo on warning
	A.EC	Overload warning 2
	A.ED	Output watt excess warning

Note 1. Deactivate the alarm about 30 minutes of cooling time after removing the cause of occurrence.

revision history

SMC Corporation

4-14-1, Sotokanda, Chiyoda-ku, Tokyo 101-0021 JAPAN

Tel: + 81 3 5207 8249 Fax: +81 3 5298 5362

URL <http://www.smcworld.com>

Note: Specifications are subject to change without prior notice and any obligation on the part of the manufacturer.

© 2011 SMC Corporation All Rights Reserved